

HyPanel Plus User Guide V3.0.1



Akubela User Guide



Smarter Home
Sweeter Life

Introduction

This guide provides an overview of the features and functions of Akubela HyPanel Plus (version 52.1.31.17).

What's New

- Optimized device UI style and icons display on the Home screen.
- Support for multi-languages.
- Optimized Auto Discovery installation.
 - Support for modifying device names and selecting device rooms during the installation.
 - Offers the option to choose whether to add detected door phones on the same LAN. If not selected, the door phone will not be detected again(Support adding the unselected ones at any time by going to the **Device Detection** screen).
- Integrated Alexa enables voice control of devices and scenes on the HyPanel Plus.
- Support integration with Google Home.
- Support grouping Sonos devices and controlling them simultaneously.
- Display device battery, temperature, and humidity information.
- Support for renaming and deleting devices directly on the HyPanel Plus.

Before You Start

Akubela allows you to configure and control your home with HyPanel devices, the user web portal and BelaHome app, with or without a cloud connection.

This section clarifies some terms you may encounter in this guide: the home center device, the user web portal, and the Auto Discovery mode.

What the home center is

The home center is the main control hub for all devices in your home. When a device is designated as the home center during the initial setup, it becomes your primary controlling center with exclusive capabilities. With the home center and the user web portal, you can tailor your smart home system including but not limited to:

- Manage all family members accounts.
- Create and personalize your automation scenes.
- Configure the default security modes and create custom modes.
- Reset arming/disarming code and the PIN password for system lock.

- Customize the functions displayed on specific panels.

Identify the designated home center

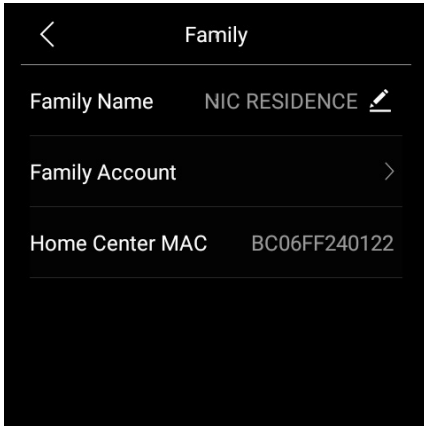

To see which device is the home center within the family, swipe down from top edge of any HyPanel Plus's screen, then tap  > **System Settings** > **About** > **Family** > **Home Center MAC**.

Login to user web portal

To log in to the user web portal, do one of the following based on the home center device's cloud connection status:

1. When connected to the cloud.

- Make sure your computer and the devices are on the same local network.
- Enter any of the device's IP address in the browser, or go to <https://my.akubela.com>.
- Log in with the family's administrator account.

How to get the administrator account? Please see [here](#).

2. When never connected with the cloud.

- Make sure your computer and the devices are on the same local network.
- Type in any of the device's IP address into the browser.
- Log in with the administrator account whose default username and password are both *Admin888*.

You can see [here](#) to learn more about the user web portal.

Usage modes

You can use devices with or without cloud connectivity, depending on how your service provider sets them up.

Auto Discovery Mode

When the Auto Discovery mode is selected in the initial setups, then the entire system runs on the same local network without a cloud connection. This mode automatically detects all HyPanel devices and door phones in the same network and can group them into one family. In this mode, your data remains on the device, not the cloud, for more privacy and security.

Devices in Auto Discovery mode can be connected to the cloud at any time. To do it, please contact your service provider.

Note that if you use the Auto Discovery mode and never establish cloud connection, all devices within your family can not receive updates pushed by the cloud server, and can not be controlled remotely via BelaHome App which, in this case, is restricted to usage within the local network.

Cloud mode

Weather broadcast on the panel's screen indicates that your devices are connected to the Cloud. In this case, all devices operate with full functionality, receiving updates pushed by the cloud server and allowing remote control through the BelaHome App.

Please be aware that if cloud-connected devices switch their network connection from the Internet to a local area network, the following functions will become unavailable:

- Reset system locks and arming code via registered email;
- Use BelaHome app when the phone connected to the Internet.

Get started

Your HyPanel Plus

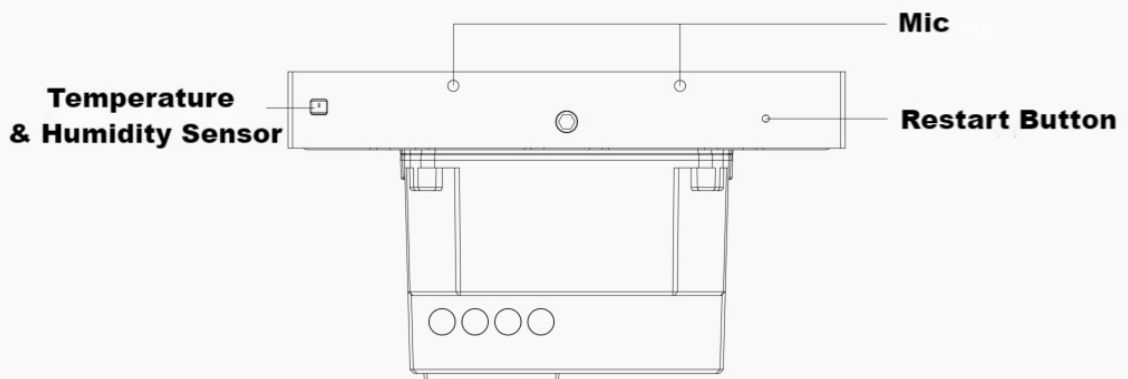
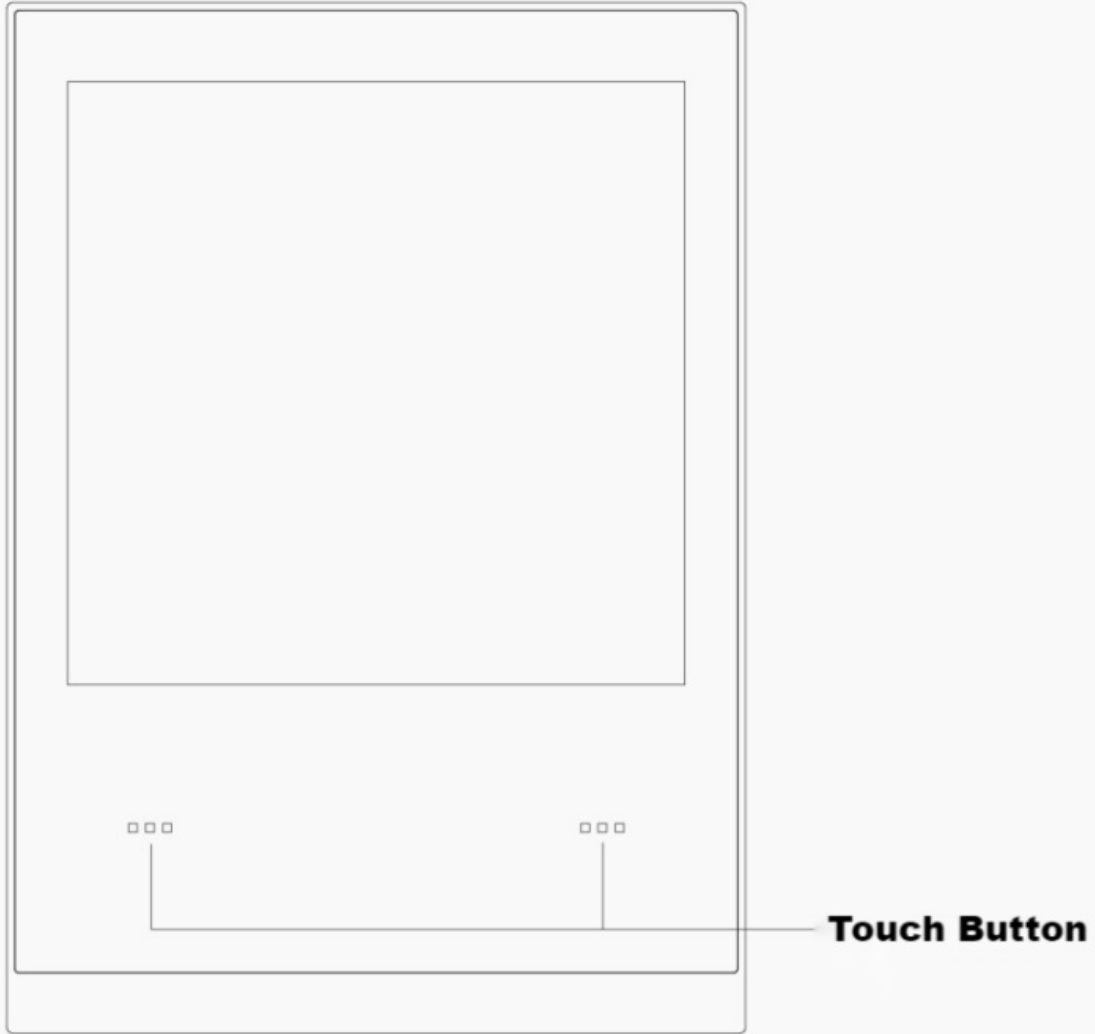

Touch buttons

The HyPanel Plus features two touch buttons at the bottom of the device. These buttons allow for quick control of selected devices and enable the direct activation of scenes with manual input. The following screen displays every time when you wake up the HyPanel Plus, displaying the functionality of the touch buttons.



To customize an unconfigured button or change its functionality, do any of the following:

- Tap the desired touch button to go directly to the Key Control screen.
- Swipe down from the top edge of any screen, tap  > **System Settings** > **Key Control**, select the desired button.

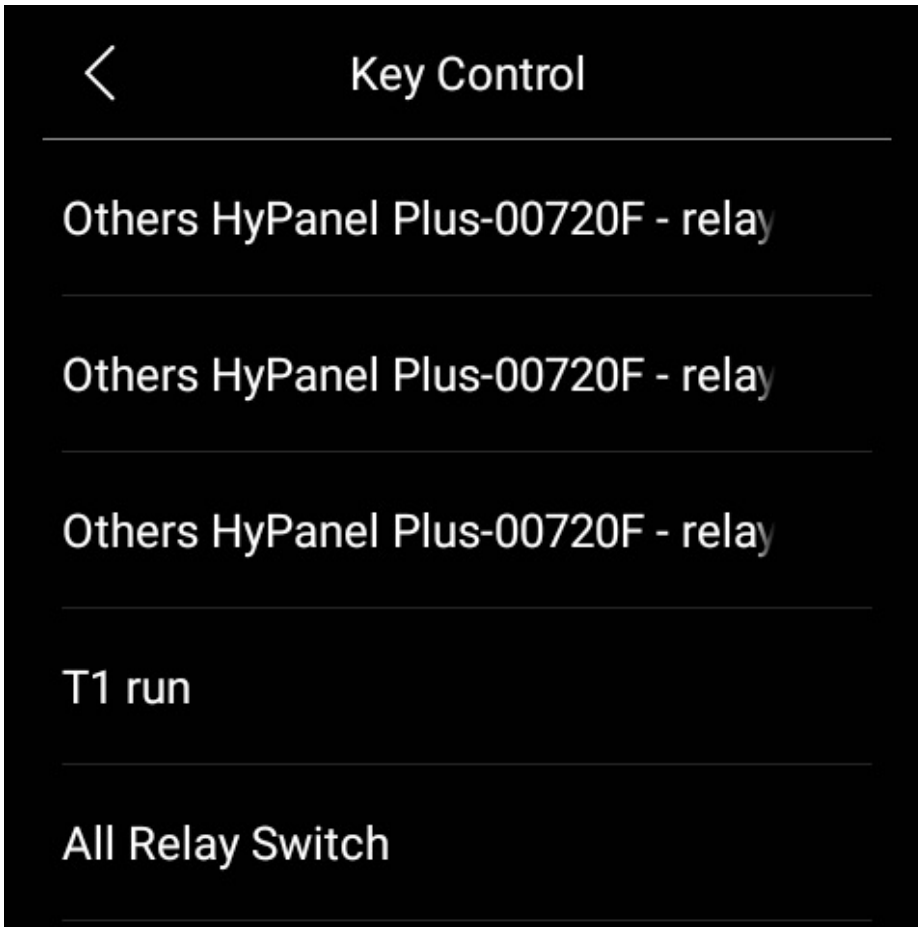

Besides, you can turn on or off the light of the buttons by going to  > **Display > Indicator Light**.

Gesture control

The dimmer version of flush mounted module allows you to swipe down with 2 fingers from any screen to control the connected dimmer.

To disable gesture control, go to  > **System Settings > Gesture**.

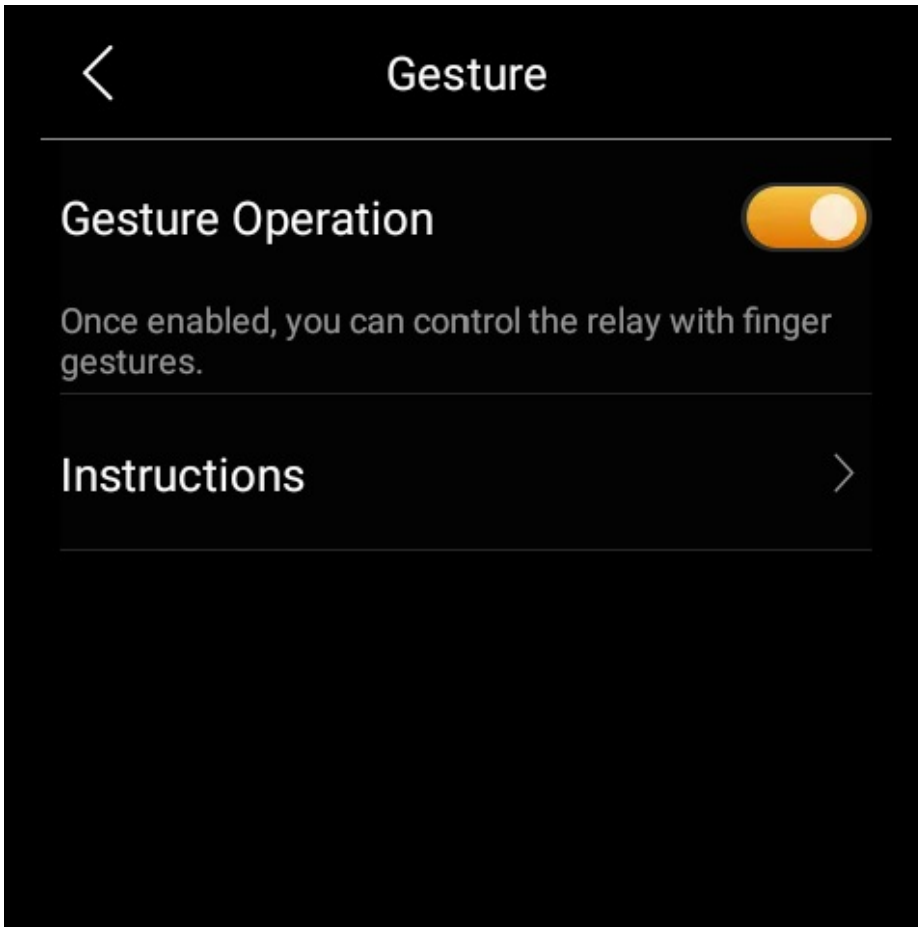

Quick control

The quick control screen provides at most 16 buttons configured to swiftly control desired devices and scenes.

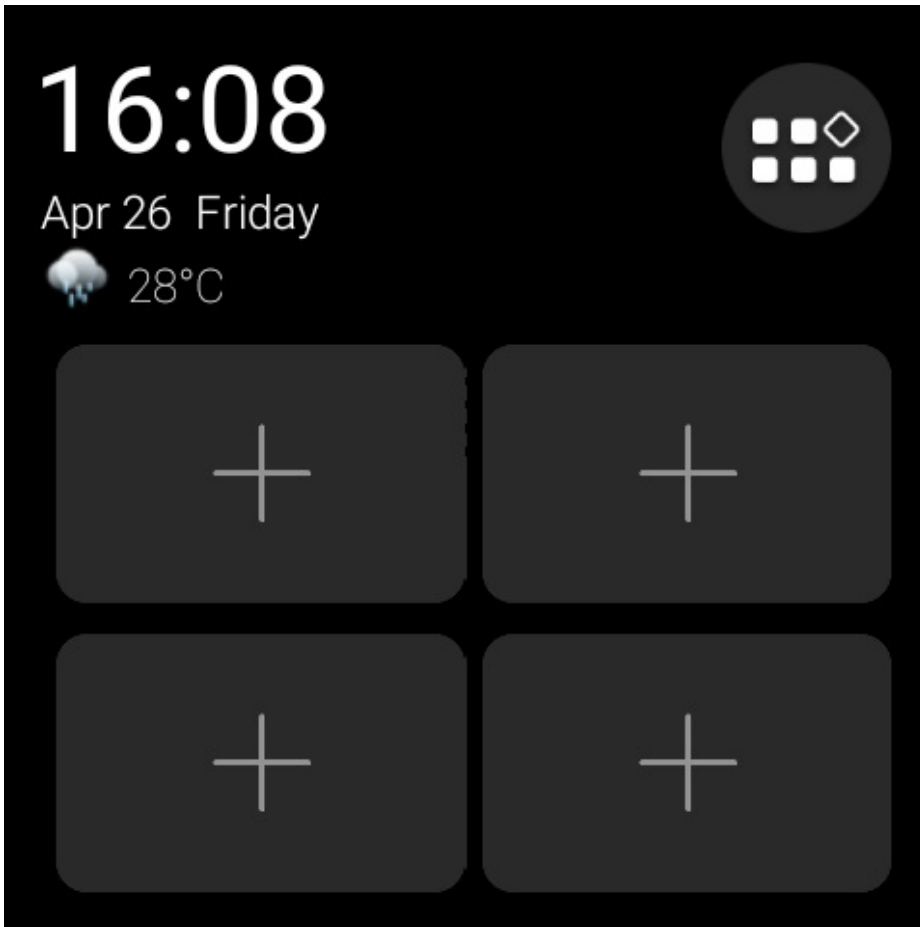

You can tap each unconfigure icon  to quickly access its setting screen,

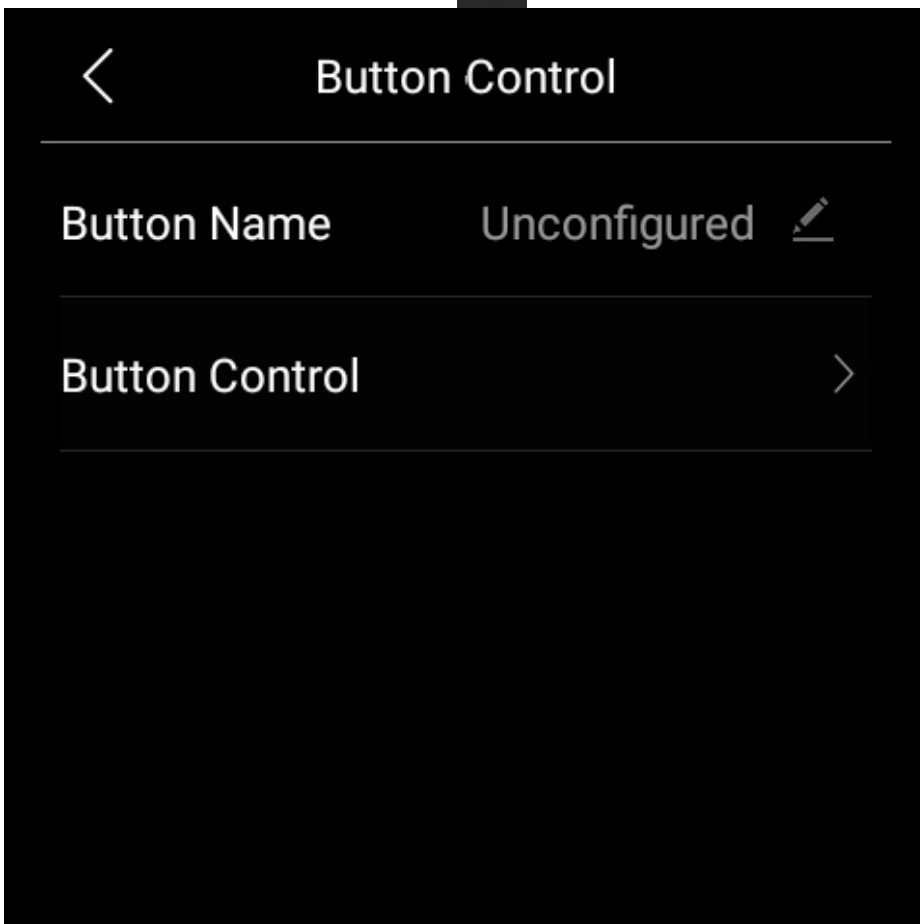

or go to  > **System Settings** > **HomePage Settings** to configure multiple buttons.

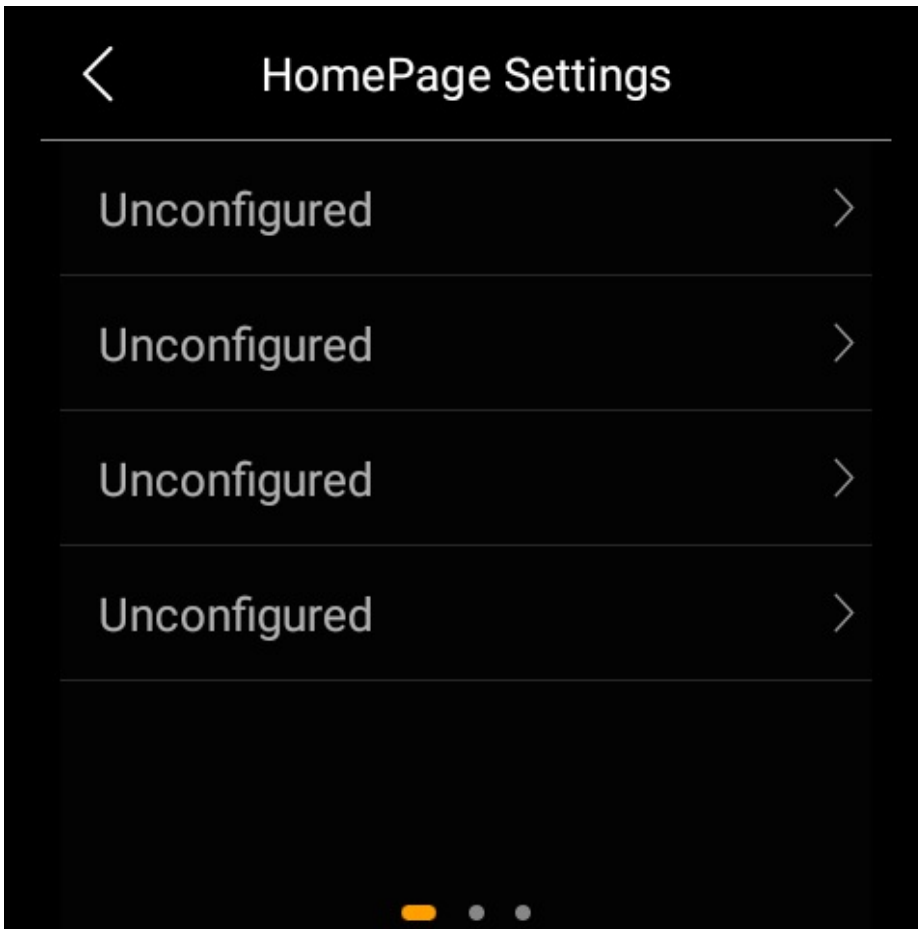

In the Homepage Settings screen, you can add two additional pages with up to 12 buttons each. To do so, swipe left and tap the icon .

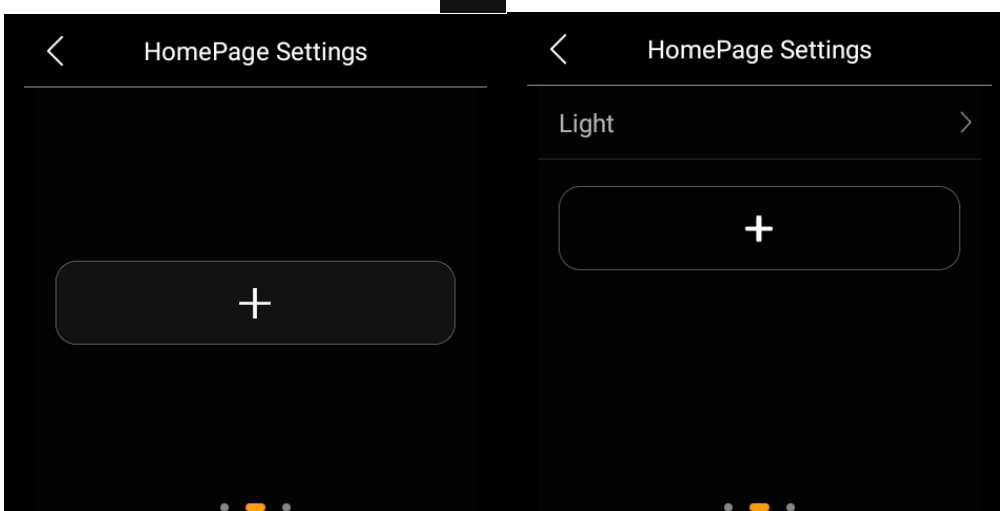

Once added, the buttons will appear on the quick control screen when you swipe left.

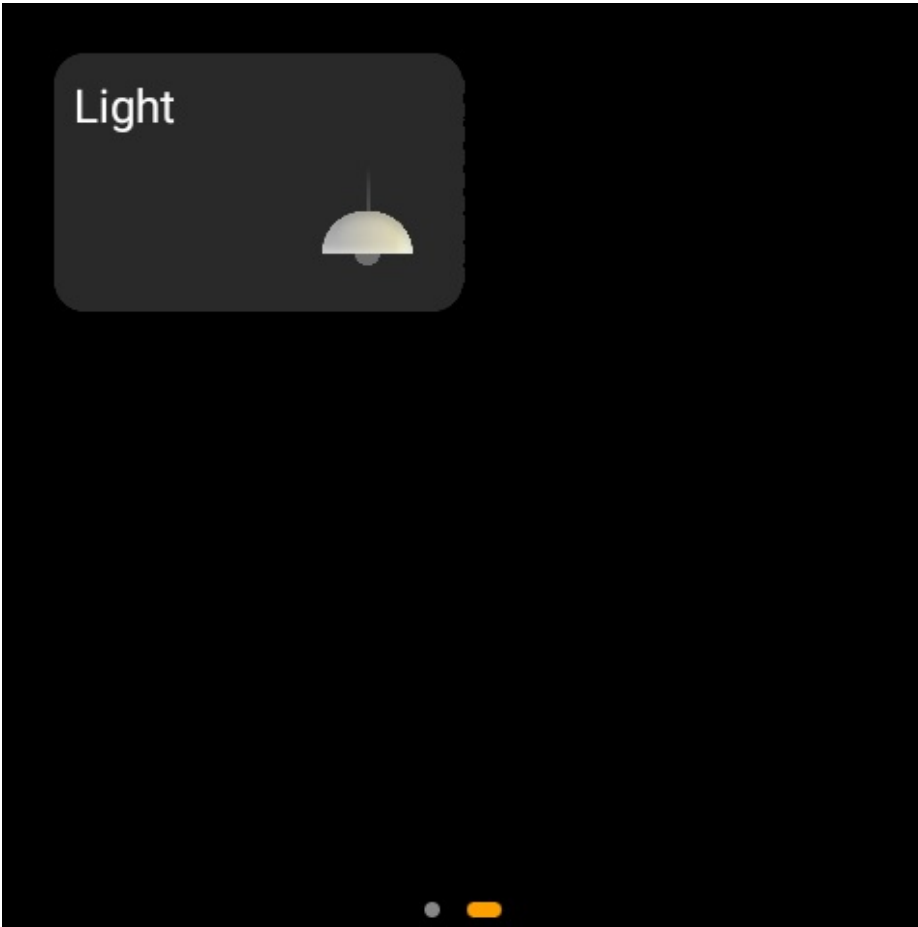

Functions screen

Tap  at the upper right of the Quick Control screen to access the Functions screen, as the below figures shown.

By default, several feature tabs are displayed on the Functions screen. When an application or a new type of device is added, a corresponding category appears. Here are some examples:

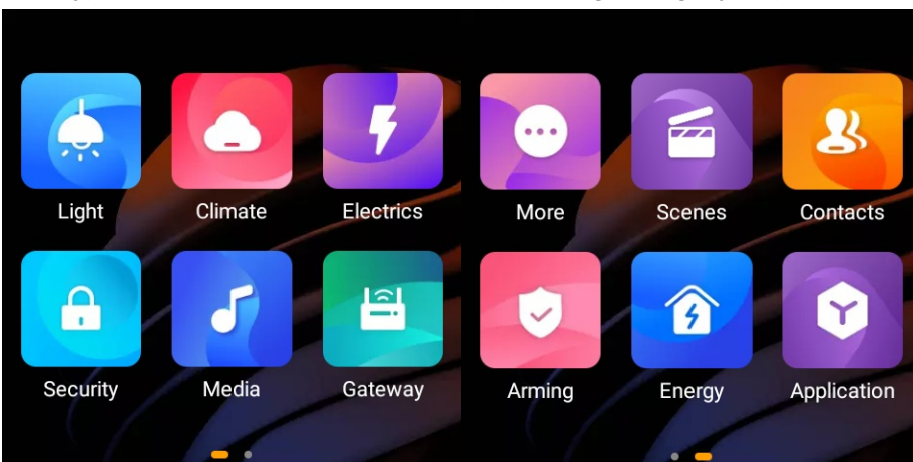

- Light: Lighting devices.
- Climate: Shades, curtains, air quality monitors, air conditioners, thermostats, cooling/heating system, and more.
- Electrics: Switches, relays, and more.

- Security: Sensors such as motion sensors, door phones, locks, cameras, and more.
- Media: Speakers, TV, and more.
- Gateway: Akubela panels.
- More: IR controllers, customized remotes, and more.
- Application: Third-party apps.

Also, you can easily customize the feature tabs shown on the [user web portal](#).

Control center

To open the Control Center for quick setting, swipe down from the top edge of any screen.

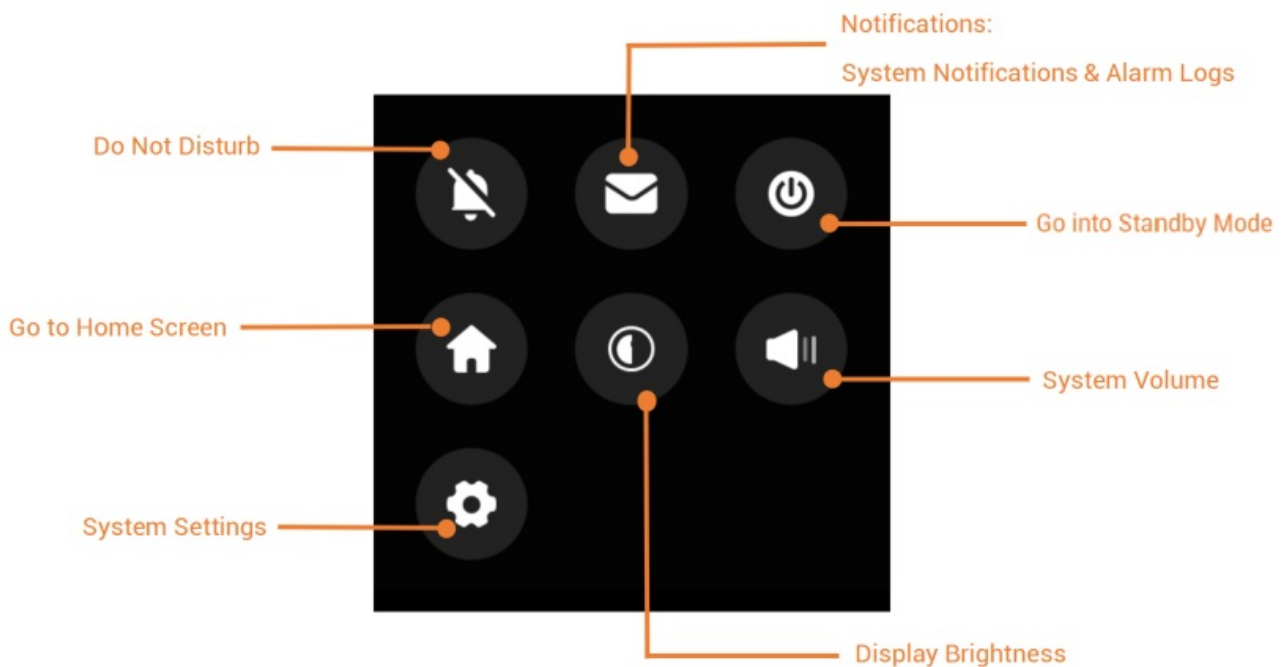

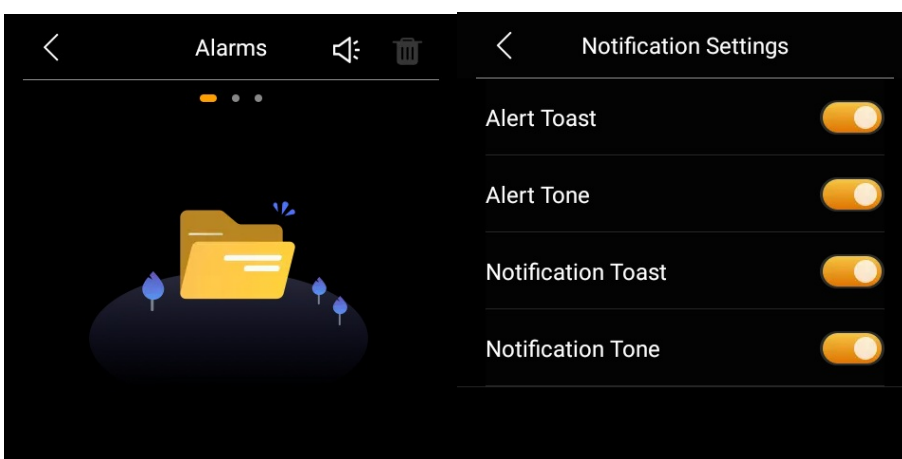

TIP :

To mute notification sounds and prevent pop-ups, simply tap  >  .



Learn the server status

When you find some features do not work, you can firstly check if the server connection is normal.

1. Swipe down from the top edge of any screen, and tap  > **System Settings** > **Connect Status**.
2. The status of your server connection will display in the center.
 - The screen that displays the icon  indicates that your device is connected to the server already.

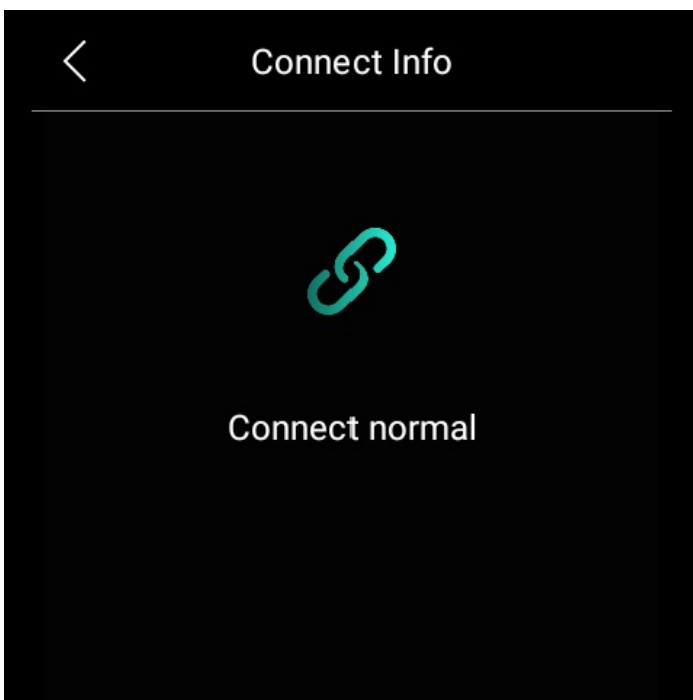

If it shows connection error, contact your service provider or Akubela technical team for help.

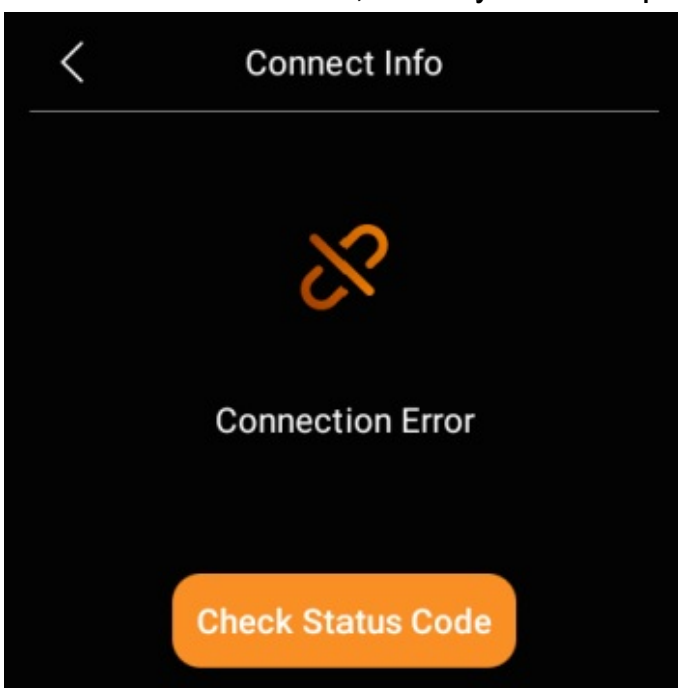

Personalize Your System

Connect to the Internet

Typically, the network is configured by your service provider during installation. You can modify the Wi-Fi network or connect the device to a local area network (LAN) anytime, be aware that it may affect certain functions. To ensure continued proper operation, please check with your service provider before making any network changes.

NOTE :

All panels within the family should be in the same local network to ensure the proper communication. If you need to use SIP call and BelaHome app's remote control function, panels must be connected to the cloud and Internet.

Change your Wi-Fi network

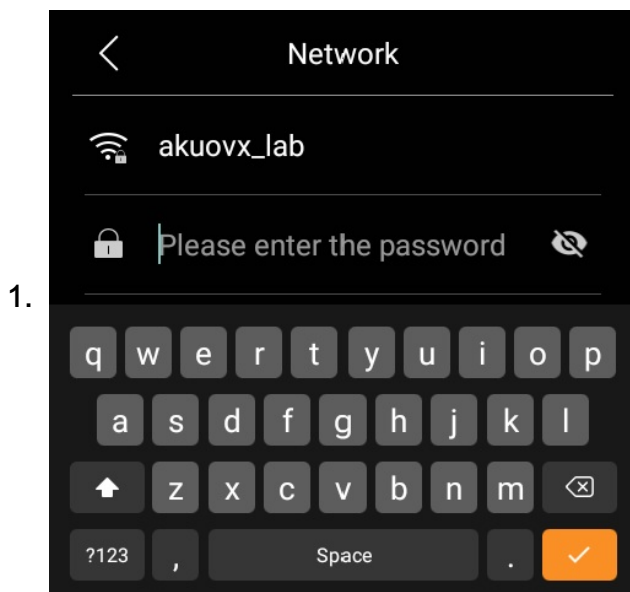

Swipe down from the top edge of any screen to open Control Center, and tap  > Wi-Fi.

2. Choose the network you want to join.
3. Enter the password if required, and tap  > **Connect**.

To see the connected network IP address, click the icon  in the upper right corner.

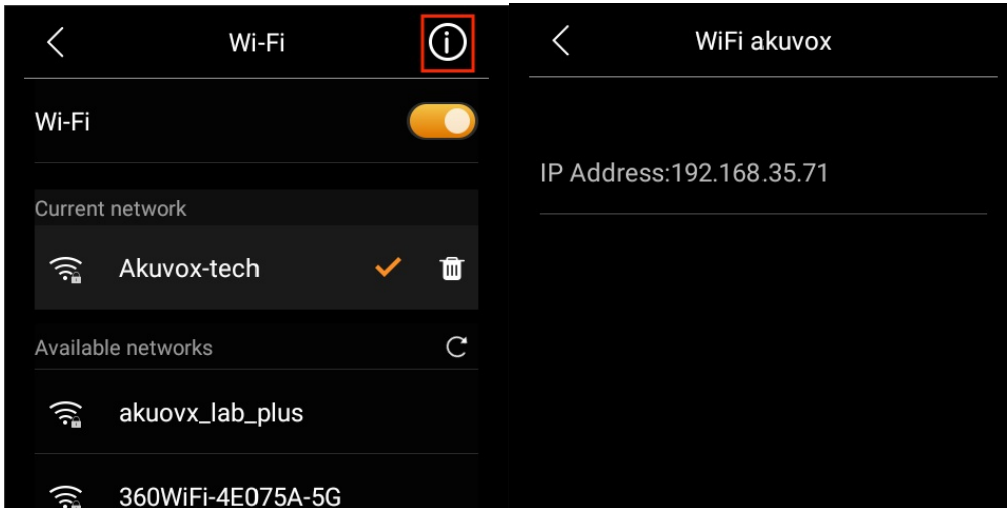

Configure LAN network

You can configure a LAN network if needed.

1. Swipe down from the top edge of any screen to open Control Center, and tap  > **Ethernet**.
2. On the Network view, do any of the following:
 - Toggle on DHCP feature, and the device will be assigned IP address automatically.

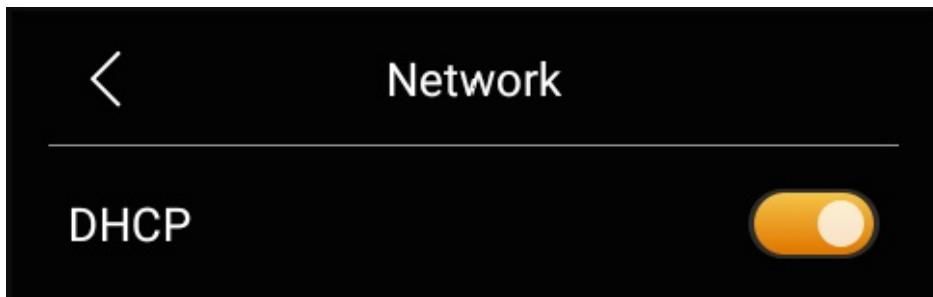

- Toggle off DHCP feature, and enter IP Address, Sub-net Mask, Gateway, Preferred DNS Server, and Alternate DNS Server manually.

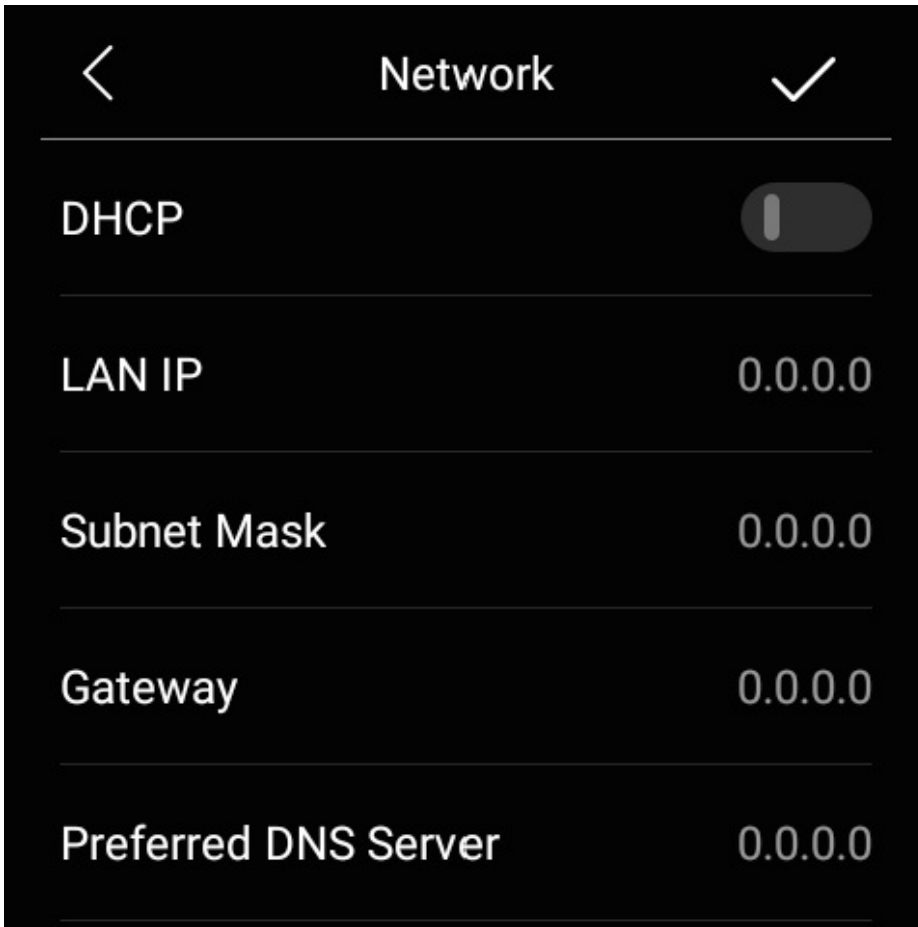

Put HyPanel Plus in standby mode

To put HyPanel Plus in standby mode quickly, swipe down from the top edge of any screen to open Control Center, then tap .

You can customize how long the device takes to enter the standby mode by tapping  > **Display** > **Go into Standby**. For example, if you choose 1 min, then HyPanel Plus will enter standby mode in 1 minute of inactivity.

Change screen saver settings

In Display Settings, you can turn the screen saver on or off, and choose the screen saver style.

1. Swipe down from the top edge of any screen, then tap  > **Display**.

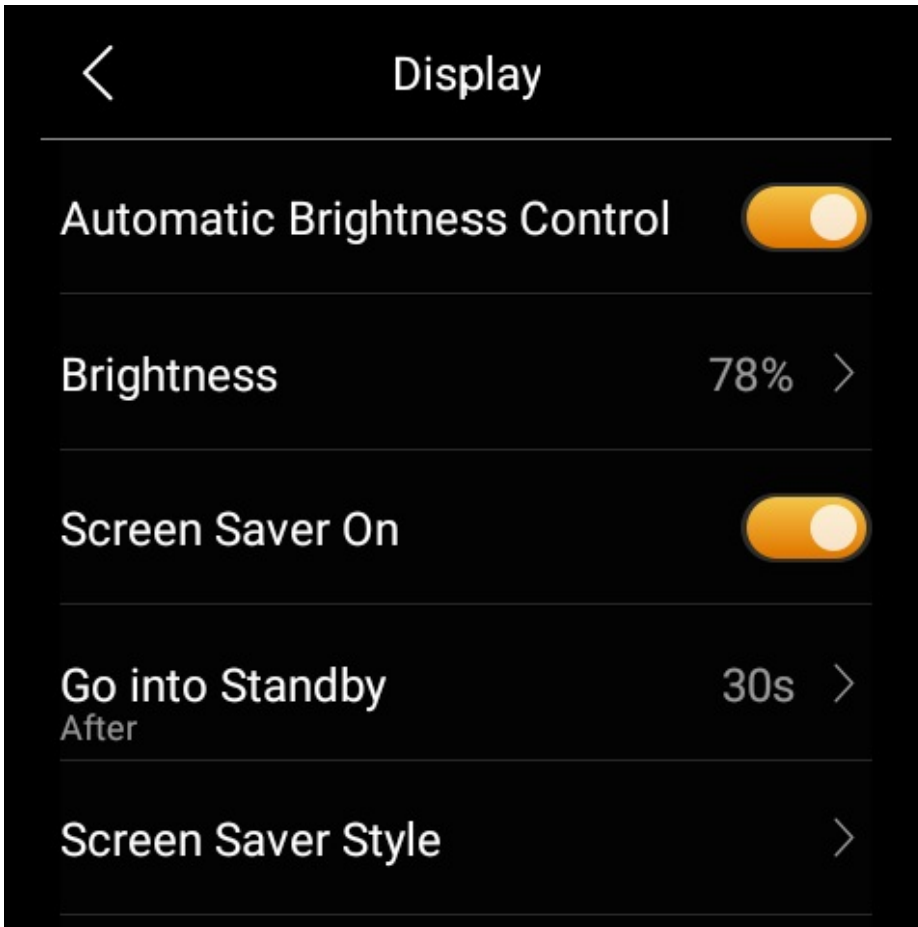

2. Do any of the following:

- Turn on or off the the toggle next to **Screen Saver On**.

When it is enabled, HyPanel Plus in standby mode will display photos and images; when disabled, the display just stays off.

- Choose a screen saver style.

Select **Photo Wall** from the pull-down menu if you want to play images.

To add your preferred photos, see [here](#).

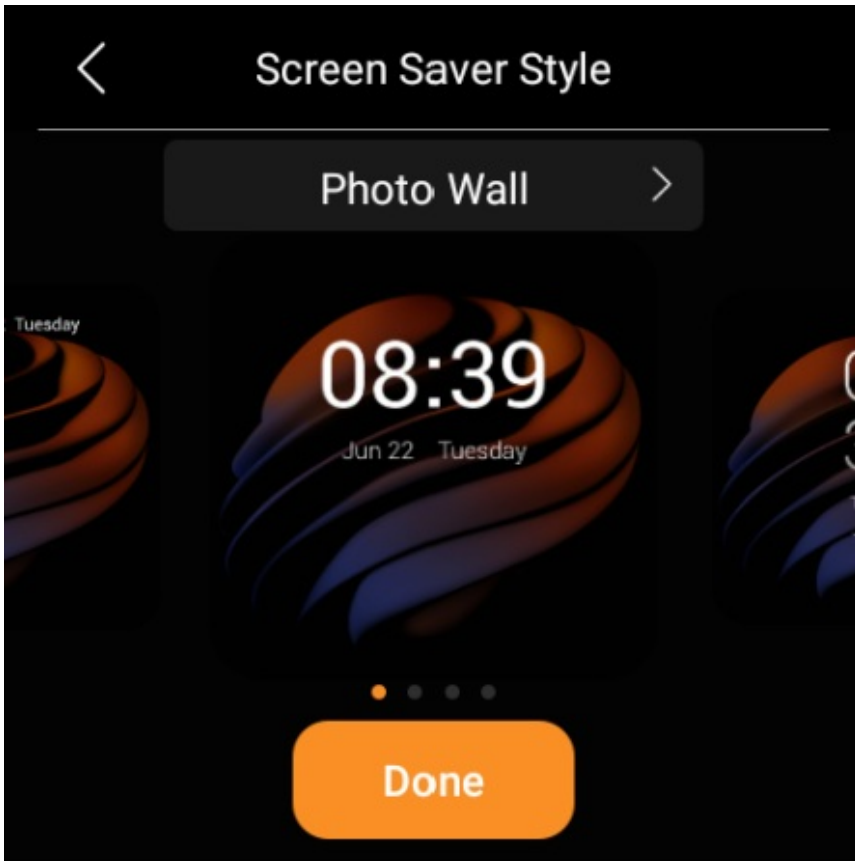



- Schedule the screensaver to turn on automatically by selecting Screen Saver Times.

Set up Do Not Disturb

If you do not want to be disturbed by calls, messages, or notifications, you can turn on the Do Not Disturb (DND) feature.

Quickly Turn DND on or off

You can quickly turn the DND feature on by swiping down from the top edge of any screen, and tapping . The icon will turn to  when the DND is enabled. Tap the icon again to turn the DND off.

This feature can also be set up by going to  > DND.

Schedule the DND to turn on automatically

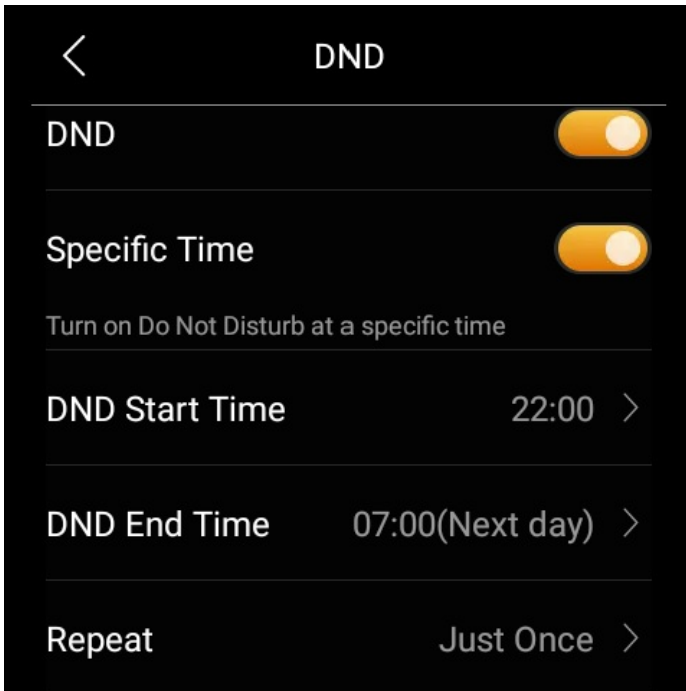

To schedule a DND to turn on automatically at certain times, do as the following:

1. Swipe down from the top edge of any screen to open Control Center, and tap  > DND.
2. Toggle on DND.
3. Toggle on Specific Time.
4. Set the DND start time and end time. DND will be activated automatically during the designated period and deactivated outside these hours.
5. Specifies the number of times the DND schedule will be repeated. The default setting is 1 time.

Once you set the DND, all the calls and notifications will be silenced in this period, while the alarm still rings.

Protect your HyPanel Plus

For better security, use screen lock or settings lock to prevent unintended access to your device or the settings screen.

Set up system lock

1. Swipe down from the top edge of any screen to open Control Center, and tap  > System

Lock.

2. Do any of the following:

- Toggle on **Screen Lock** to set a pattern password to unlock the screen when you wake it, and follow the onscreen instructions.

- Toggle on **Setting Lock** to prevent unwanted access to the Settings screen, and follow the onscreen instructions.



NOTE:

The Screen Lock and the Settings Lock share the same pattern password. When both of the locks are enabled, you only need to draw the pattern password once to access the device and the Settings screen.

To change the pattern password, on this System Lock screen, tap **Set Screen Lock Password**, draw the current pattern, and then set a new password.

Forgot password

To clear the forgotten current password, tap **Forgot Password** on the password required screen and follow the onscreen instructions. Two resetting options are provided based on your cloud connection status.

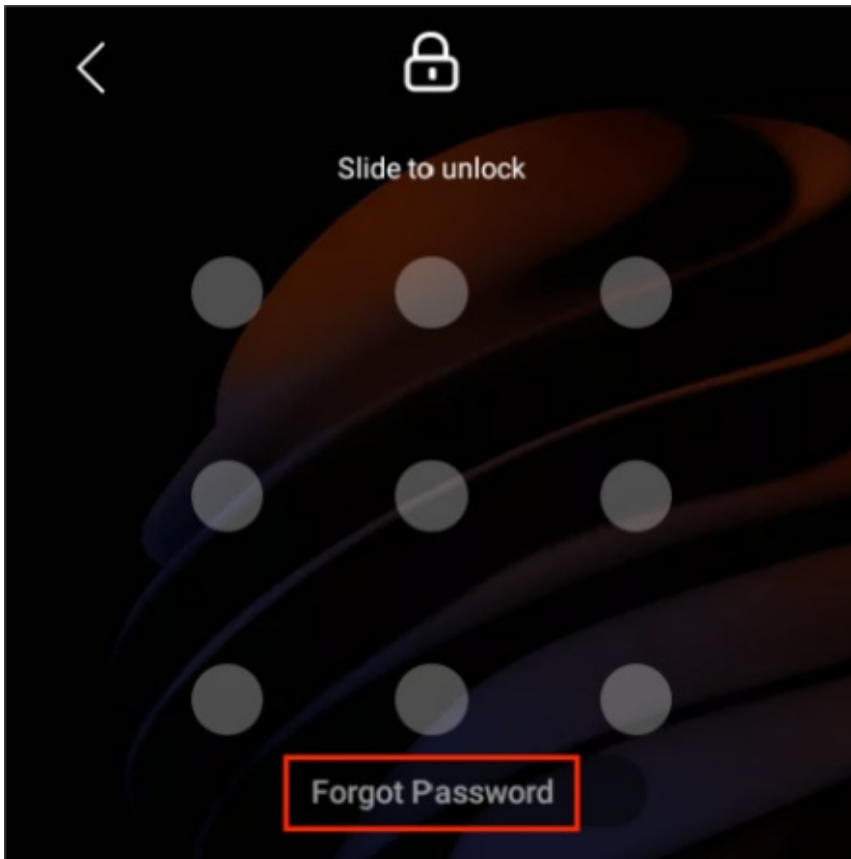

- Via reset email

If you've registered the administrator account and ensure that the devices are connected to the Internet, a password reset email will be sent to the family's administrator email address once you tap Forgot Password. Follow the instructions included to clear the password.

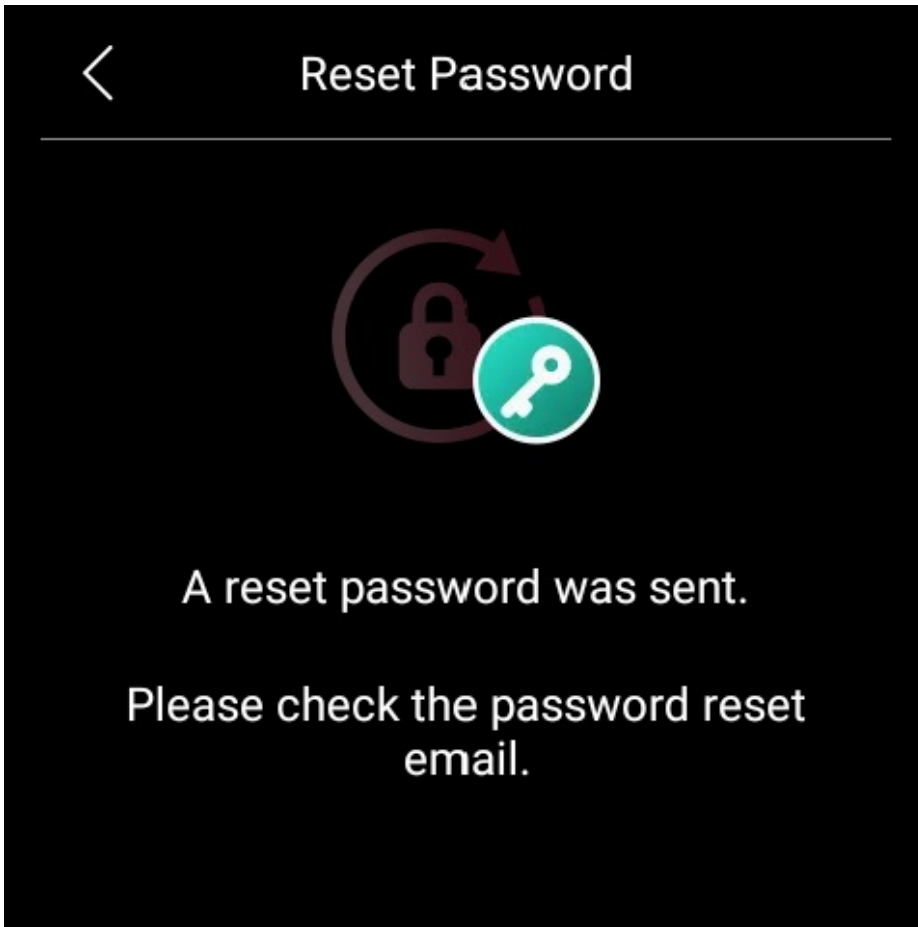

- On the user web portal

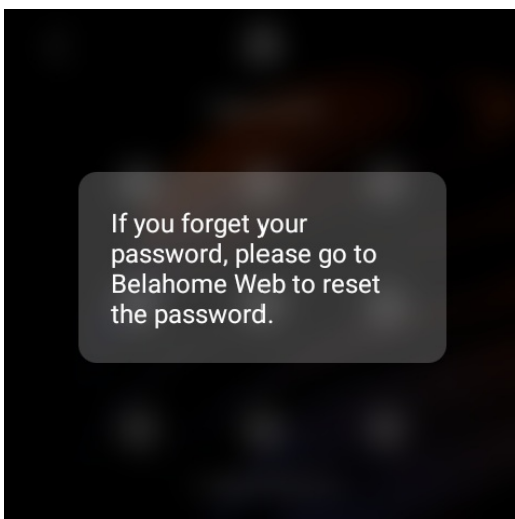

Visit the user web portal, find the specific HyPanel Plus, and click  > **Reset** > **Reset Panel screen lock password**.

You can see [here](#) for the detailed instructions.

Manage Devices

Add ZigBee Devices

HyPanel Plus can connect to many ZigBee devices, such as sensors, emergency button, IR controller, thermostat, smart switch, and more. For example, you can add and fit a CO sensor in your kitchen to identify carbon monoxide leaks.

NOTE:



The transmission distances of ZigBee signal may vary by environmental characteristics and more. For optimal performance, add ZigBee devices to the HyPanel Plus within the same room.







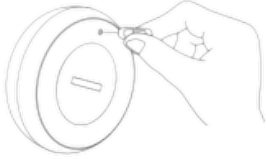

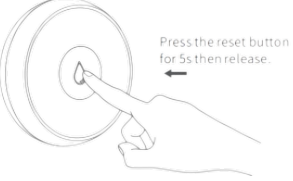
Put Devices in pairing mode

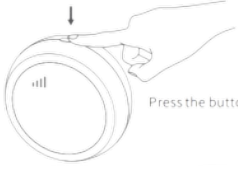
Before pairing the ZigBee devices with the HyPanel Plus, you should know how to activate their pairing mode. Here are a few examples to guide you.

TIP:

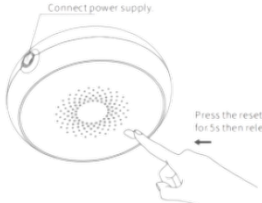

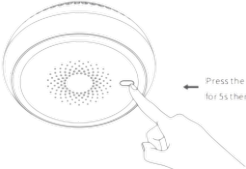
For more additional devices, check our guide on [Put ZigBee Devices into Paring Mode](#), or refer to their manuals.

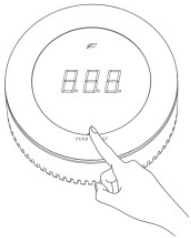
| ZigBee device | How to put it to the pairing mode | |
|---|--|---|
|  <p>Smart Emergency Button</p> | <p>Insert a pin into the reset hole at its back cover for 5 - 10s until the green light flashes quickly.</p> |  |
|  <p>Smart Flood Sensor</p> | <p>Press and hold the reset button on the front for 5 - 10s until the green light flashes quickly.</p> |  |

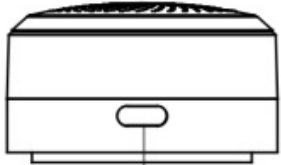
| | | |
|---|--|--|
| <p>Smart Temperature and Humidity sensor</p>  | <p>Press and hold the reset button on the side for 5 - 10s until the signal icon flashes quickly.</p> |  <p>Press the button for 5s.</p> |
| <p>Smart Motion Sensor</p>  | <ol style="list-style-type: none"> 1. Rotate the battery cover anticlockwise to open. 2. Press and hold the reset button for at least 5s until the green light flashes quickly. |  <p>Press the reset button for 5s then release.</p> |
| <p>Smart Gas Sensor</p>  | <p>Press and hold the reset button on the front for at least 5s until the green light flashes quickly.</p> |  <p>Connect power supply</p> <p>Press the reset button for 5s then release.</p> |
| <p>Smart Smoke Sensor</p>  | <p>Press and hold the reset button on the front for at least 5s until the green light flashes quickly.</p> |  <p>Press the reset button for 5s then release.</p> |
| <p>Smart CO Sensor</p>  | <ol style="list-style-type: none"> 1. Power on the sensor, and wait for its indicator light to change from yellow to green. 2. Press and hold the button on the front for at least 5s until the green light flashes quickly. |  <p>Long press the button for 5 seconds and release.</p> |

| | | |
|--|---|--|
| <p>IR Controller</p>  | <p>1. Power the controller by connecting it to a wall charger using the included USB cable.</p> <p>1. Press and hold the button on the side of the controller until the green light flashes slowly and a beep sound is heard.</p> |  <p>LED indicator Networking button</p> |
|--|---|--|

Pair devices with HyPanel Plus

1. Swipe down from the top edge of any screen to open Control Center, and tap  > **Device Management** > . HyPanel Plus will then search for the nearby ZigBee devices.

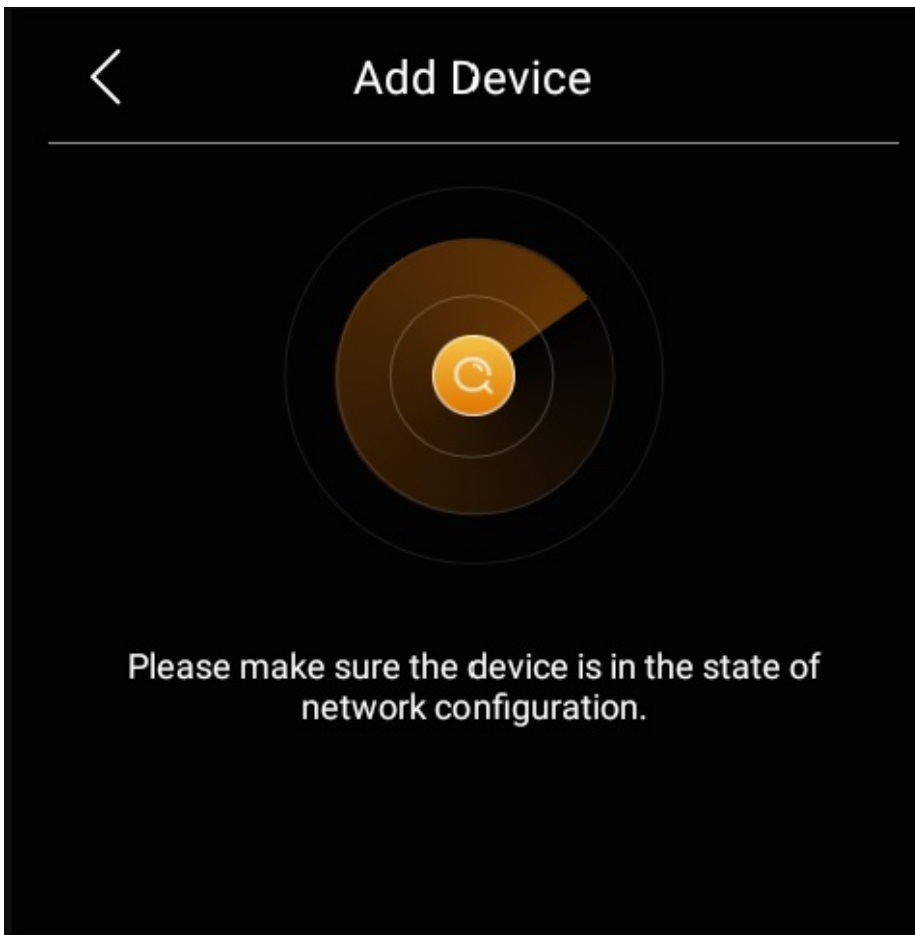

2. Put the ZigBee device you want to add in pairing mode.
3. The screen displays the searched device. Select it, and tap **Next**.

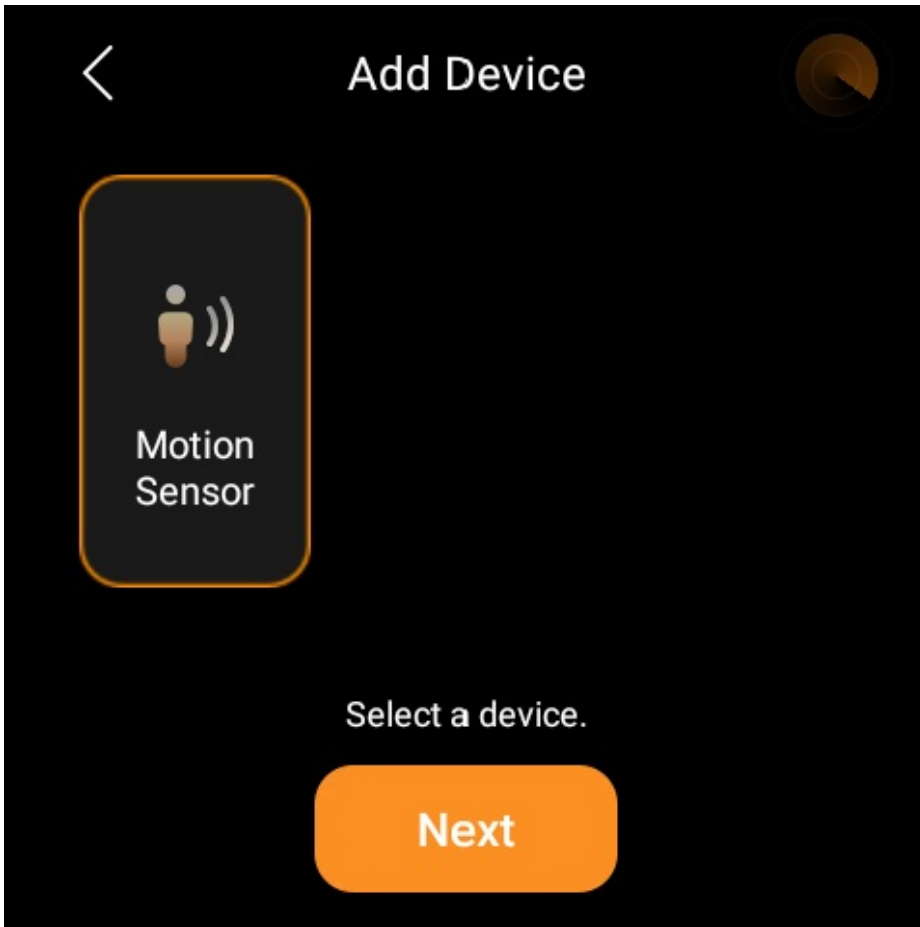

NOTE:

If the device appears as Unknown, you can set its type before proceeding to the next step.

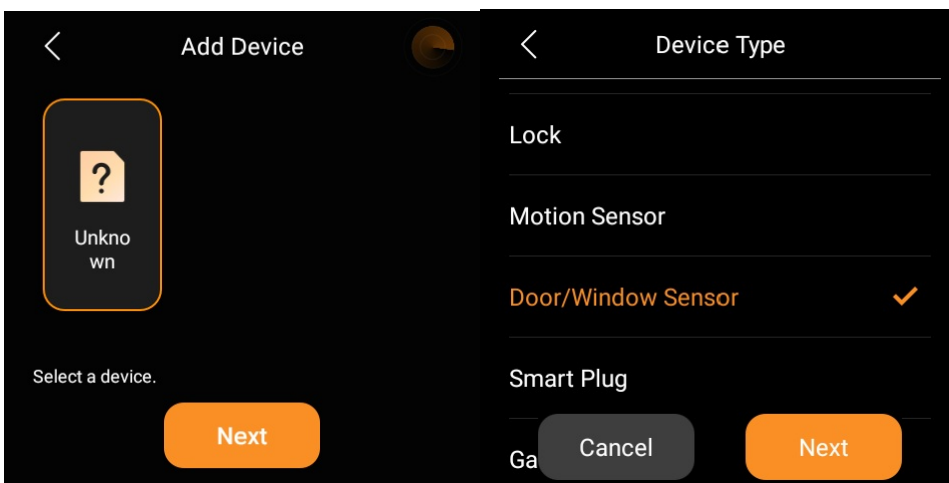

4. Name the device and choose its location, tap **Done** > **Next**.

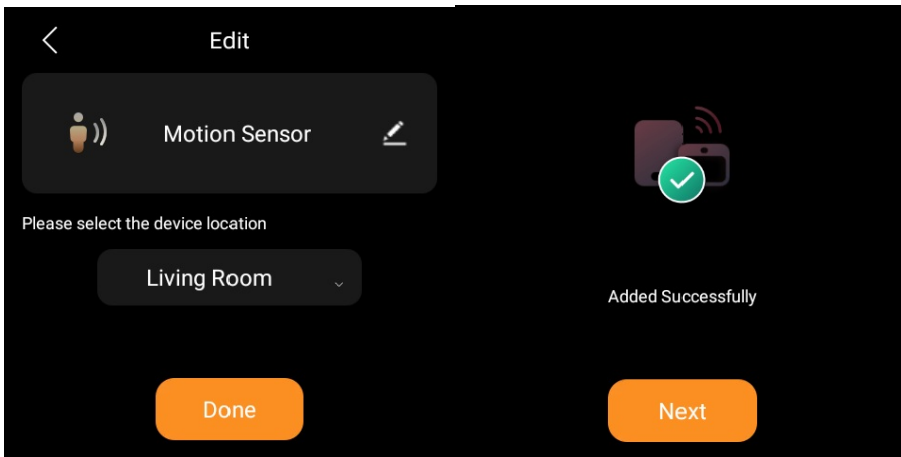

5.The newly added device will be shown on both Device Management screen and the corresponding category screen.

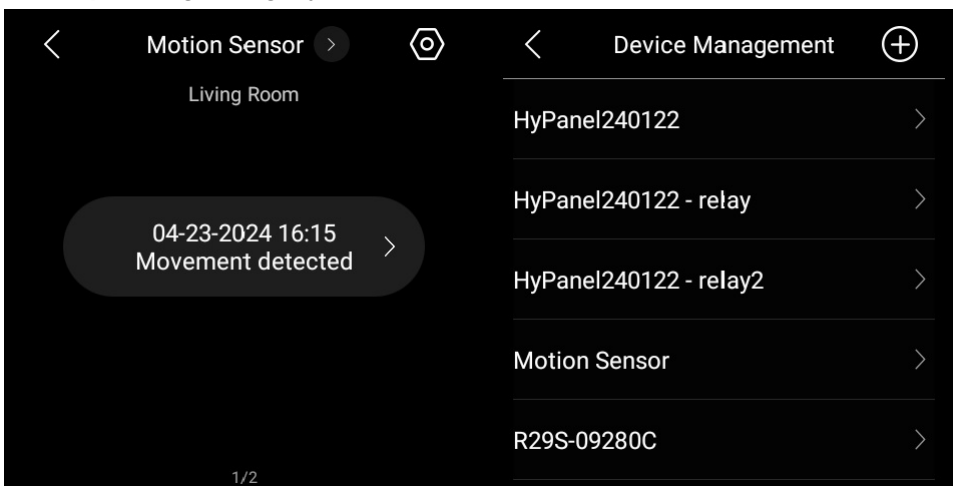

You can also learn more about how to delete added ZigBee devices from the [user web portal](#) or [BelaHome app](#).

Add third-party smart home devices

Third-party smart home devices, such as Philips Hue, Ring Video Doorbell, Ecobee thermostat, Lutron Caseta, TP-Link kasa, Sonos, and more, can be added or removed on user web portal, or via BelaHome App.

To add a device, refer to any of the instructions:

- [Using BelaHome app](#);
- [On the user web portal](#).

See trigger histories of sensors

To see trigger histories of sensors, go to the corresponding catalog screen, select the desired sensor, and tap the logs.

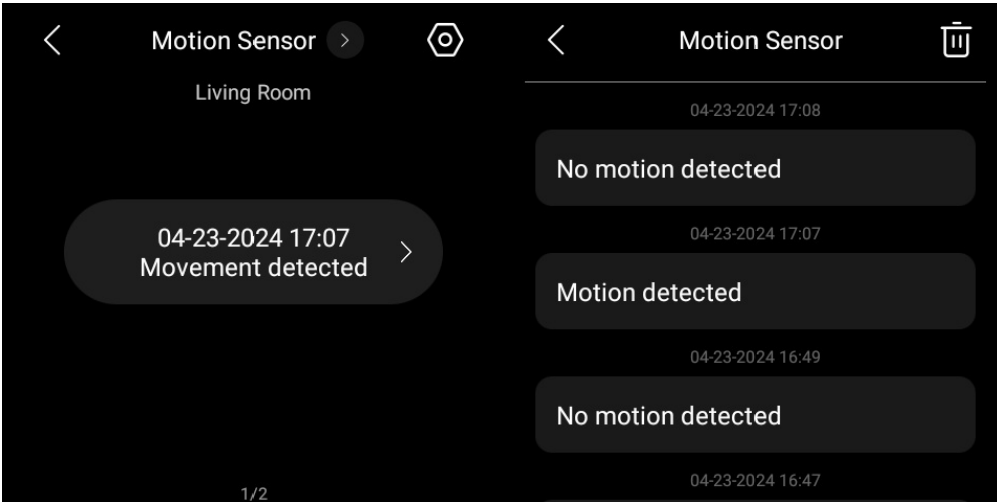

To delete records, simply tap the icon  in the upper right corner, select the logs, and tap **Delete**.

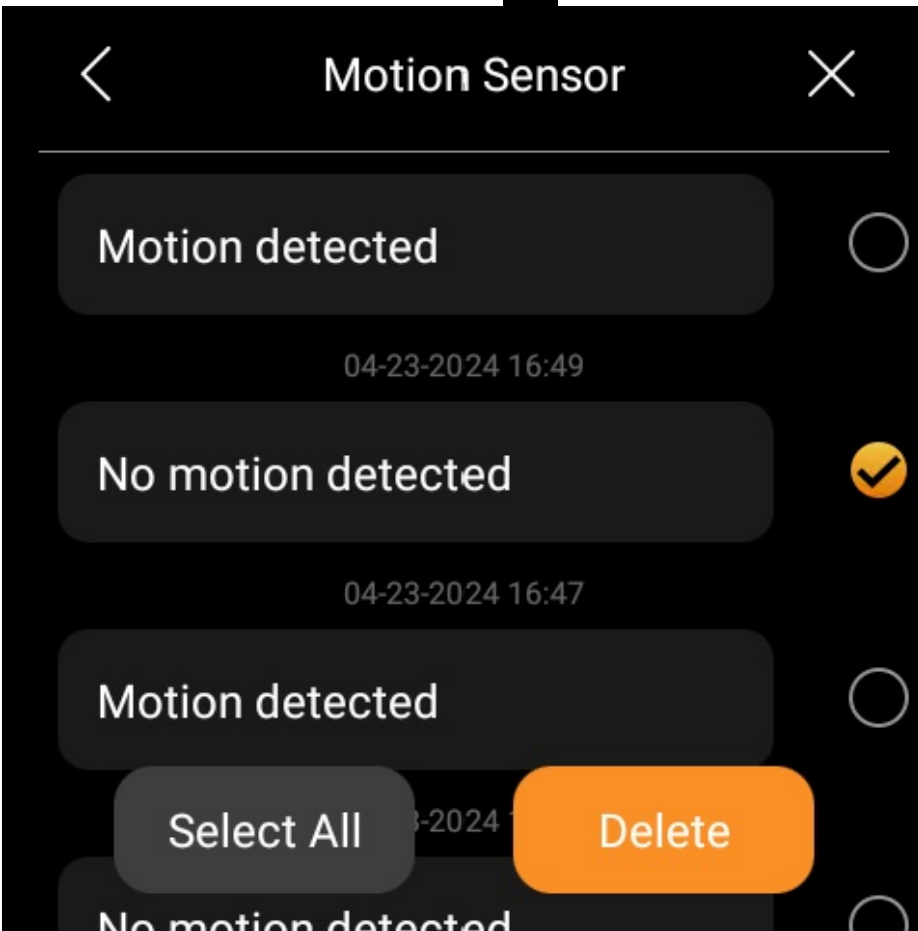



Modify and delete devices

To view the details, relocate, or delete a device, do any of the following. Note that you can delete sensors, door phones, and third-party devices like lights directly on the panel. For other panels or devices, use the app or user web portal.

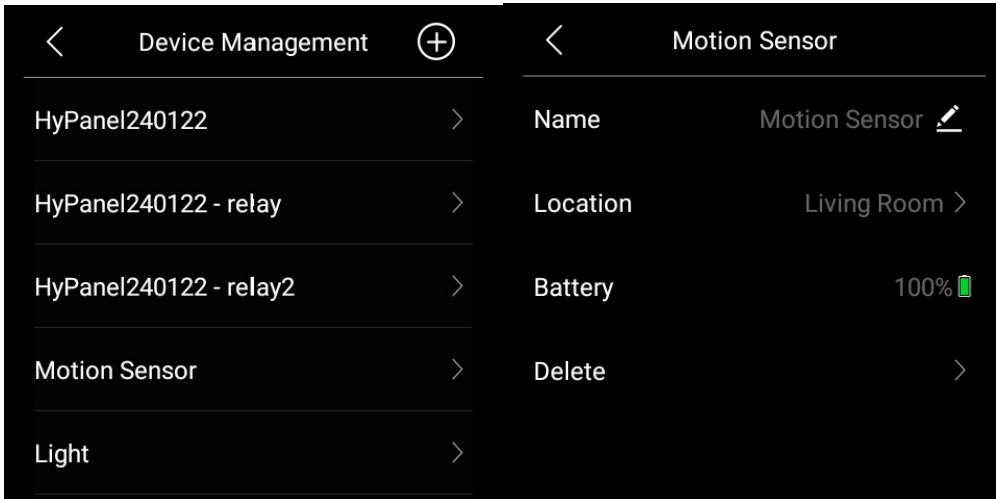
- Go to  > **Device Management**, and select the desired device.



- Tap  to go to the Functions screen, select a desired category, and tap .

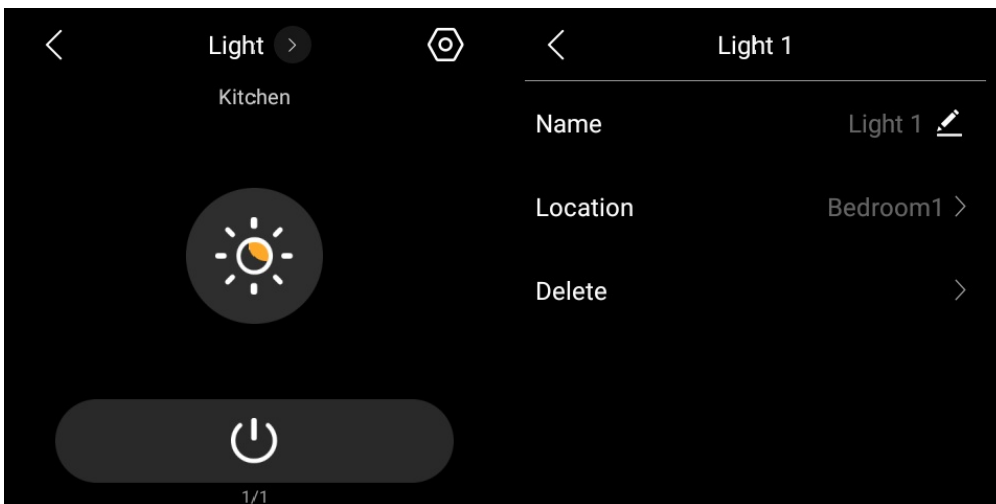

- [Using BelaHome app.](#)
- [Go to the user web portal.](#)

Control devices

Relays

The F51-R2-EU version of HyPanel Plus allows direct connection to two relays whose type can be switch, light, fan, heating/cooling system, and shade. You need to change the default relay type to the one you need via BelaHome app. For the detailed instructions, see [here](#).

To open a relay, go to the Electrics  screen, and tap the button at the center. It turns to be highlighted, indicating that the relay is opened.

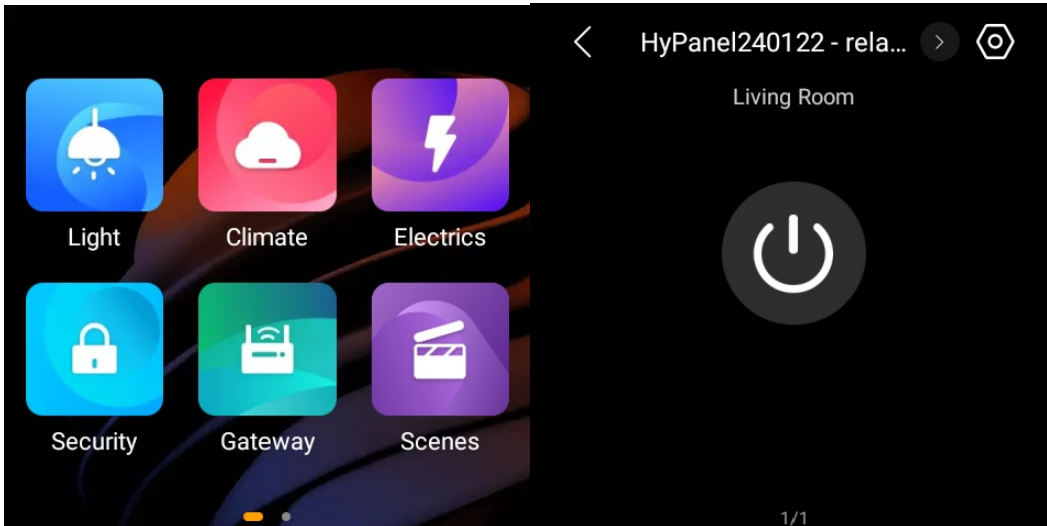

To close the relay, tap it again, and its background dims.

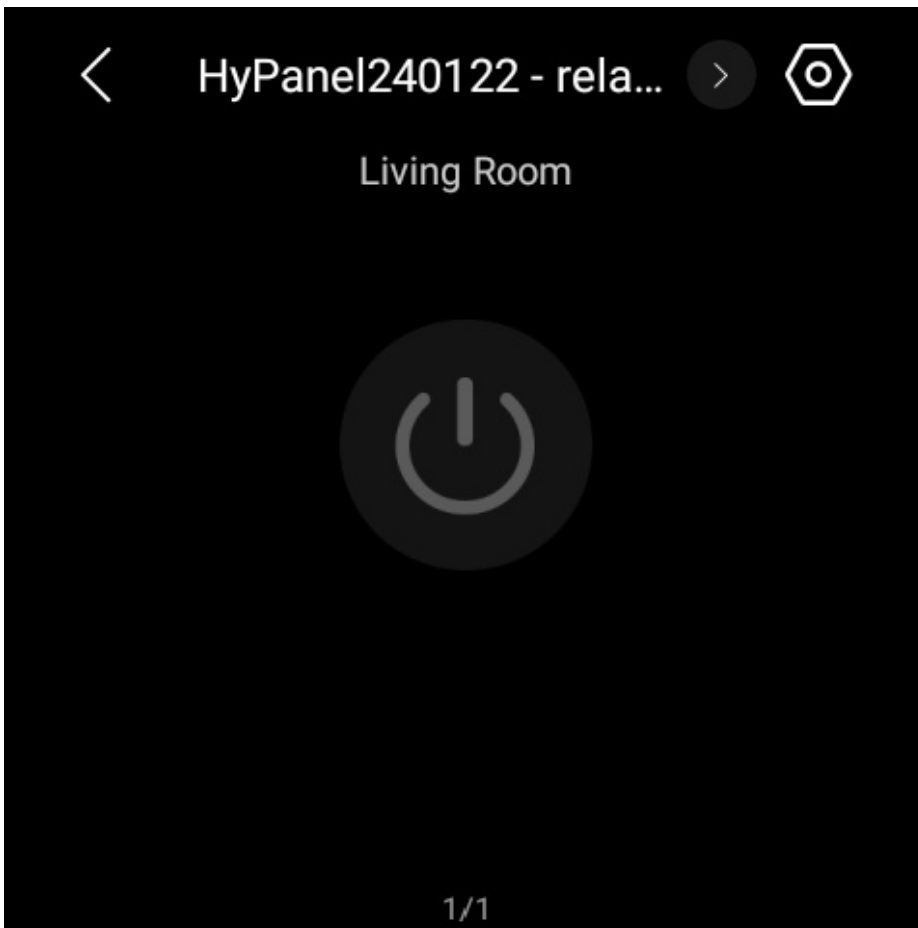

Also, you can control a relay by tapping the button on the Quick Control screen, provided that you have configured it. To see detailed instructions, click [here](#).

Switch, plug, and socket





To turn on your switch, socket, siren or a light, on their specific function screen, tap the desired device. Its background becomes highlighted, indicating that it is opened.

Lighting

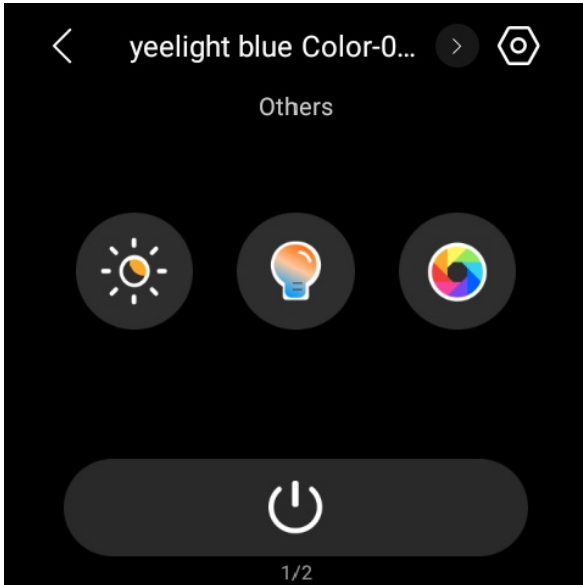
Some lights can only be turned on or off with a single tap, while others like RGB lights, offer more features such as color adjustment, brightness control, and so on.

To control a RGB light, do the following:



1. Go to the **Light** screen.
2. Swipe through the screen to find the desired device, or tap  to select from the list.
3. To turn the light on or off, tap .
4. To adjust its brightness, tap , then drag the slider.
5. To change the color temperature, tap , then drag the slider.
6. To set the light color, tap , and then pick the desired color from the palette.



Heating, cooling, and thermostat

Heating and cooling

Go to the **Climate**  screen, swipe through the screen to find the desired device, or tap 

to select from the list. Then do any of the following:

- To close/open the device, tap the icon  at the button.



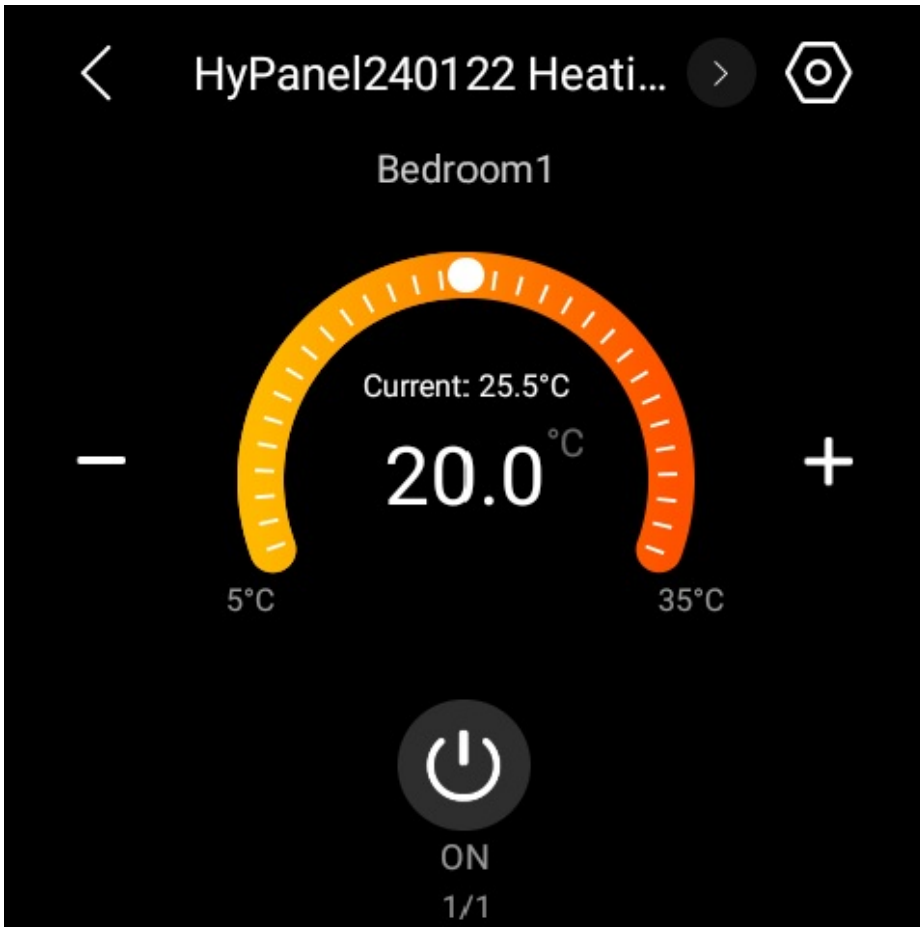

- To adjust the target temperature, tap **-** or **+**, or simply drag the slider.







Thermostat





To control the thermostat, go to the **Climate**  screen, swipe through the screen to find the desired device, or tap  to select from the list. Then do any of the following.



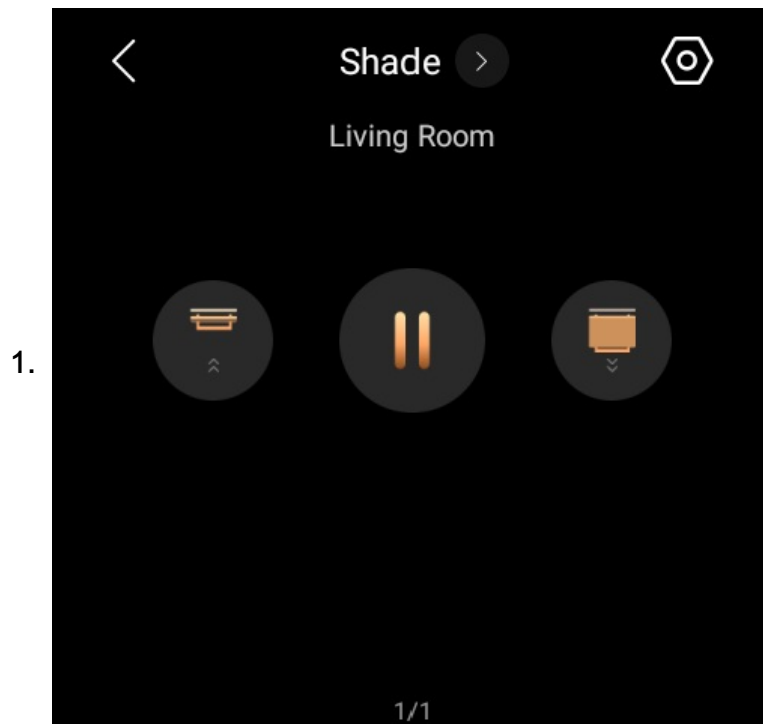

1. Tap the icon  at the bottom to switch modes.

2. Tap  or , or drag the slider, to adjust the desired temperature which ranges from 5-35°C.
3. Tap  to set fan speed.
4. Tap  to turn the thermostat on or off.

Shade



Go to the **Climate**  screen, and find the desired shade by swiping through the screen or tapping  to select from the list.

2. Do any of the following:
 - Tap  to open the shade.
 - Tap  to close the shade.
 - Tap  to stop the shade when it reaches the desired position.
 - Tap  for advanced settings.

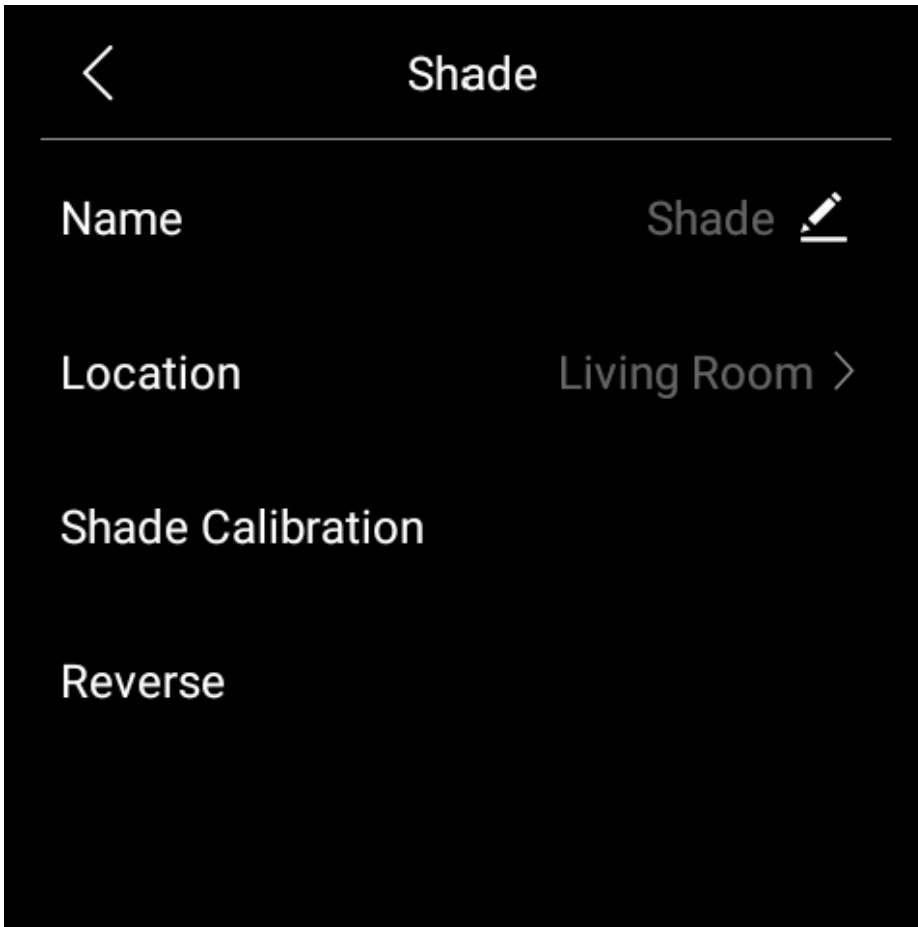

- **Shade Calibration** refers to adjusting the time it takes for the curtain to fully open and close. To do so, select this option and follow onscreen instructions.
- **Reverse** refers to reversing the curtain's movement direction when the close and open buttons operate contrary to the current direction.

Speaker

When speakers such as SONOS are added, a Media category will be visible on the Functions screen for quick control of the speakers.

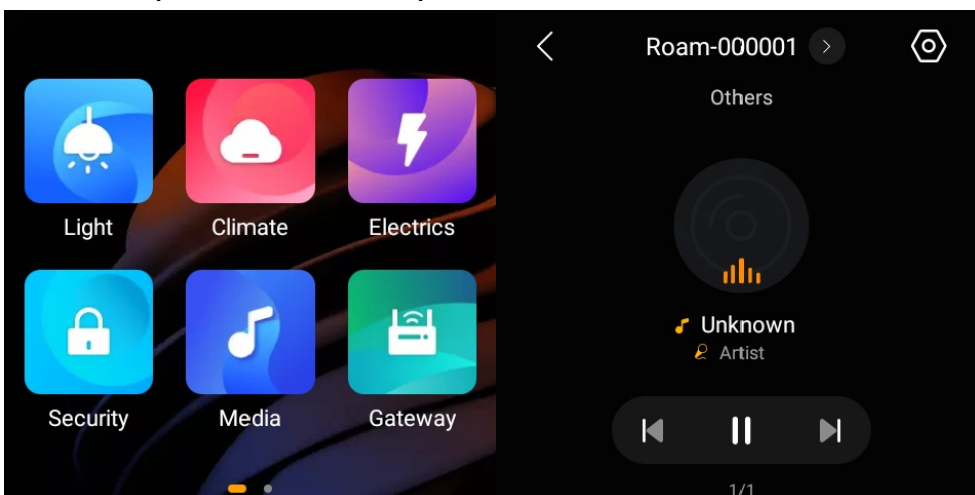

IR-based devices



Utilizing the IR controller, the panel can seamlessly integrate with up to 30 IR-based devices such as TVs and air conditioners, enabling it to function as a remote control. You can access the controller and its associated devices on the More  screen.

NOTE:

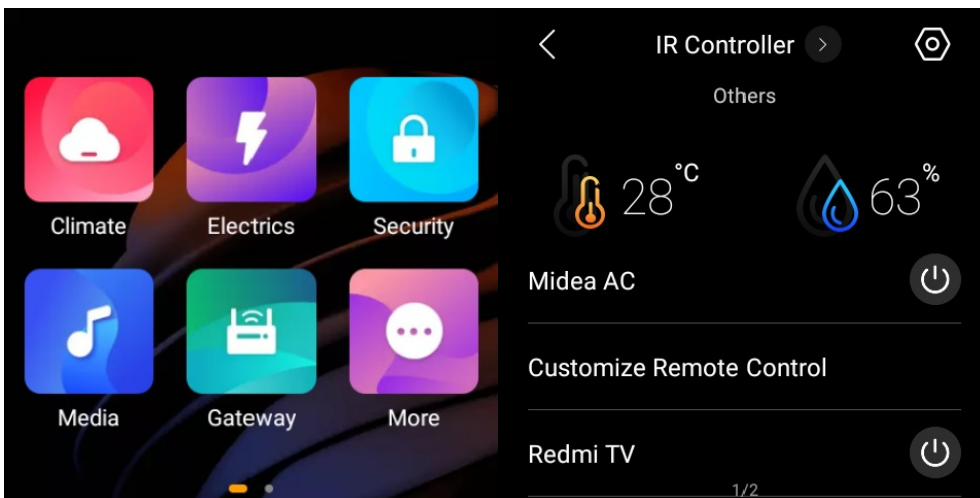
The IR-based devices should be added via BelaHome app before you can see them on panels. For detailed instructions, see [here](#).



To control the devices and remotes added by the specific IR controller, follow these steps:

- For TVs and ACs
- To simply turn them on/off, tap their respective icons  on the More screen.
- For additional functions, navigate to their corresponding feature screens:
- TV: Found on the **Media**  screen.

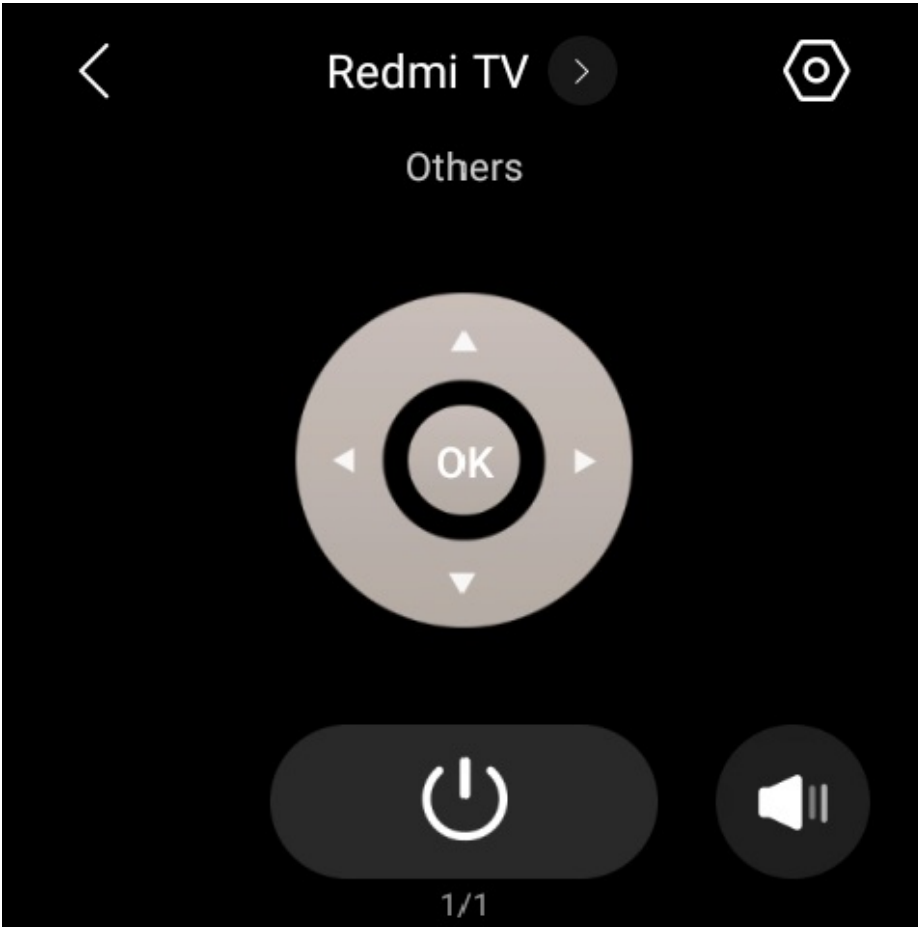

- AC: Found on the Climate  screen.



- For customized remotes

Access them on the More screen by swiping left, where the buttons you added for the remote will appear.

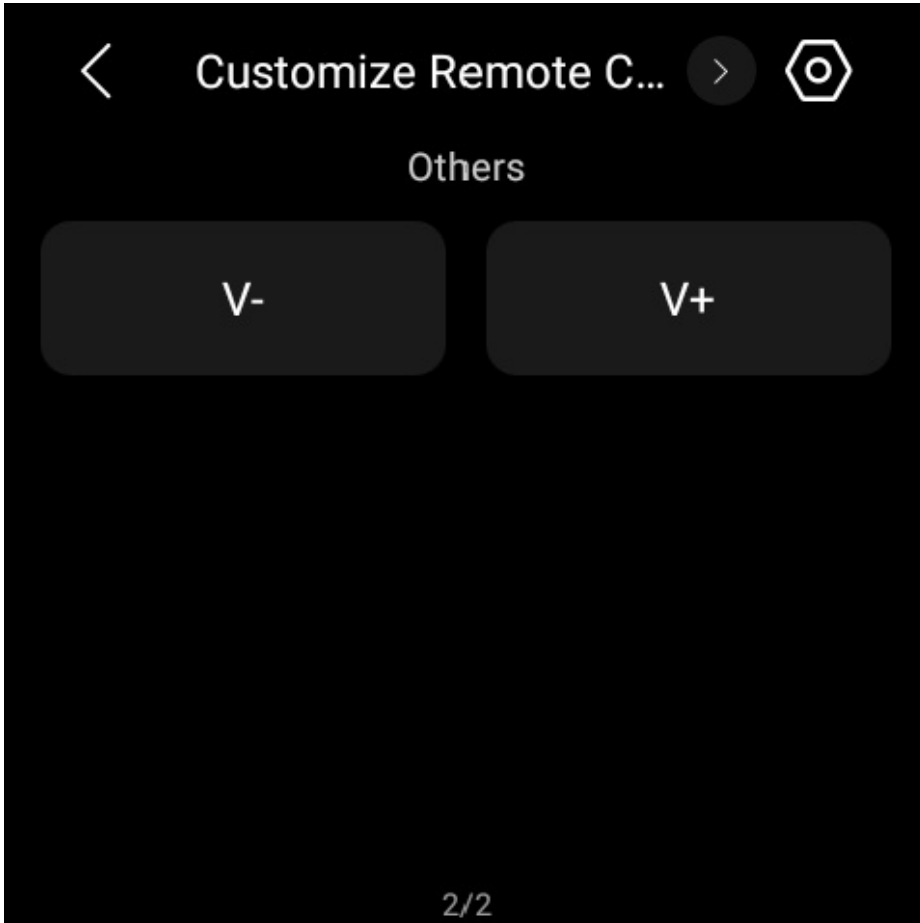

Smart lock

- Open door with one tap

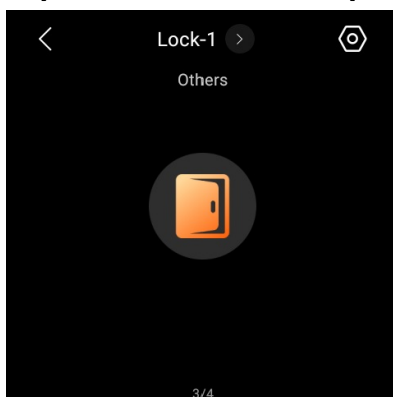

Go to the Security screen, and tap .

- Receive doorbell notification

When someone rings the doorbell on the smart lock, HyPanel Plus will display a push notification and play a sound to notify you.

- **Unlock with temporary key**

You can provide visitors with a temporary PIN for self-door unlocking. To issue such keys, refer to [the instructions with BelaHome app](#).

- **Upgrade lock's software**

To upgrade the lock's software, select the desired smart lock, and tap  > **Update**. This update option only shows up when there is a new version.

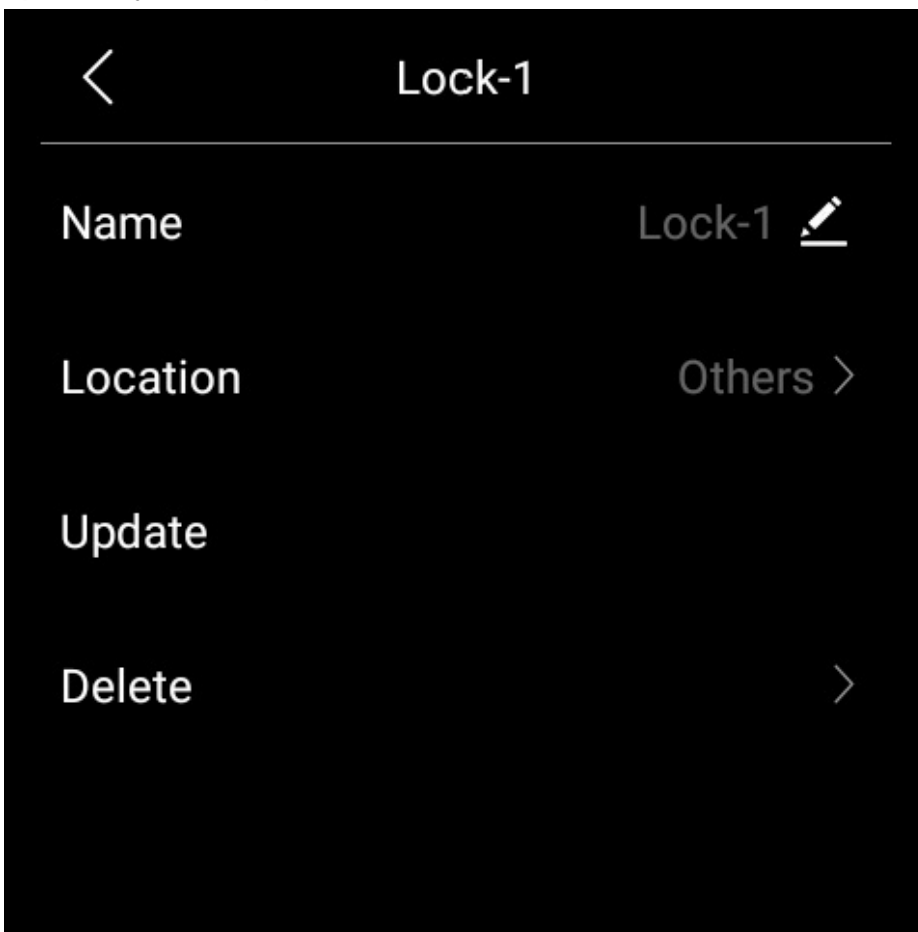

Use the intercom

HyPanel Plus enables you to add and control detected door phones on the same LAN.

NOTE:

If a door phone was not selected for addition, it will not be automatically detected the next time. To search and add the door phone again, go to  > **System Settings > About > Device Detection** screen.

Unlock door remotely

When you know who is at your door, you can open the door directly without communicating with the door phone.

1. Tap **Security**  on the Functions screen.
2. Find the desired door phone, and tap on .

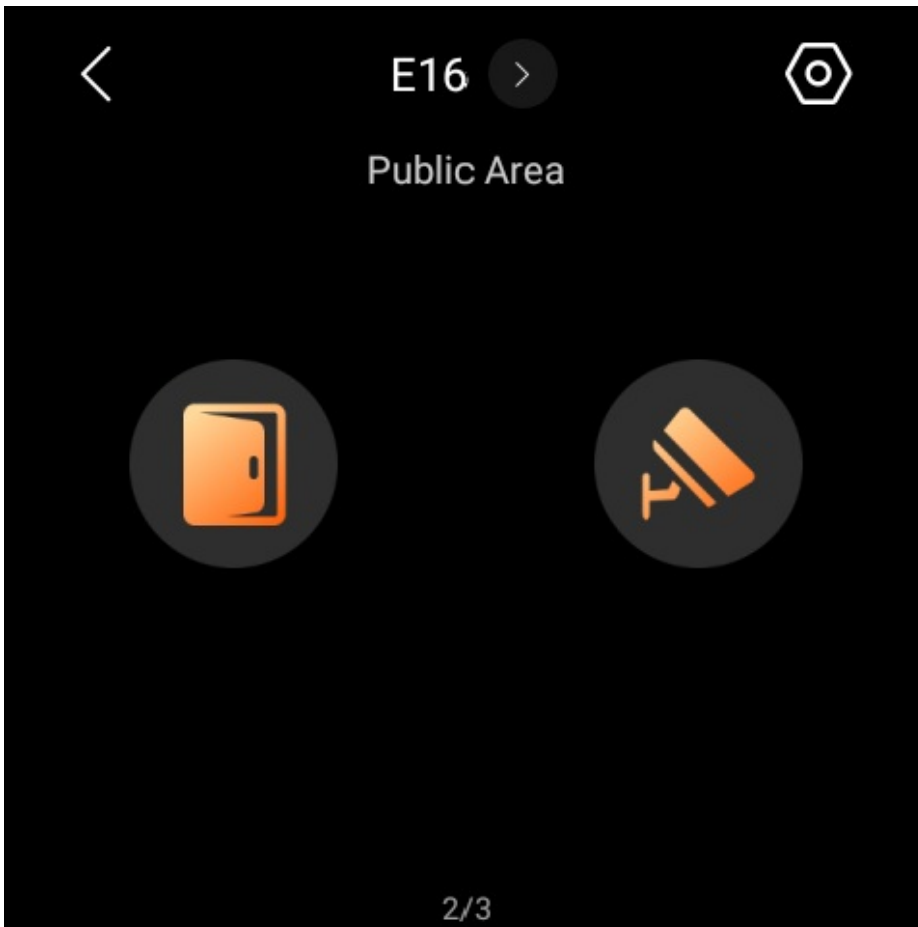

If there are multiple doors connected to the door phone, select the desired one from the pop-up list.

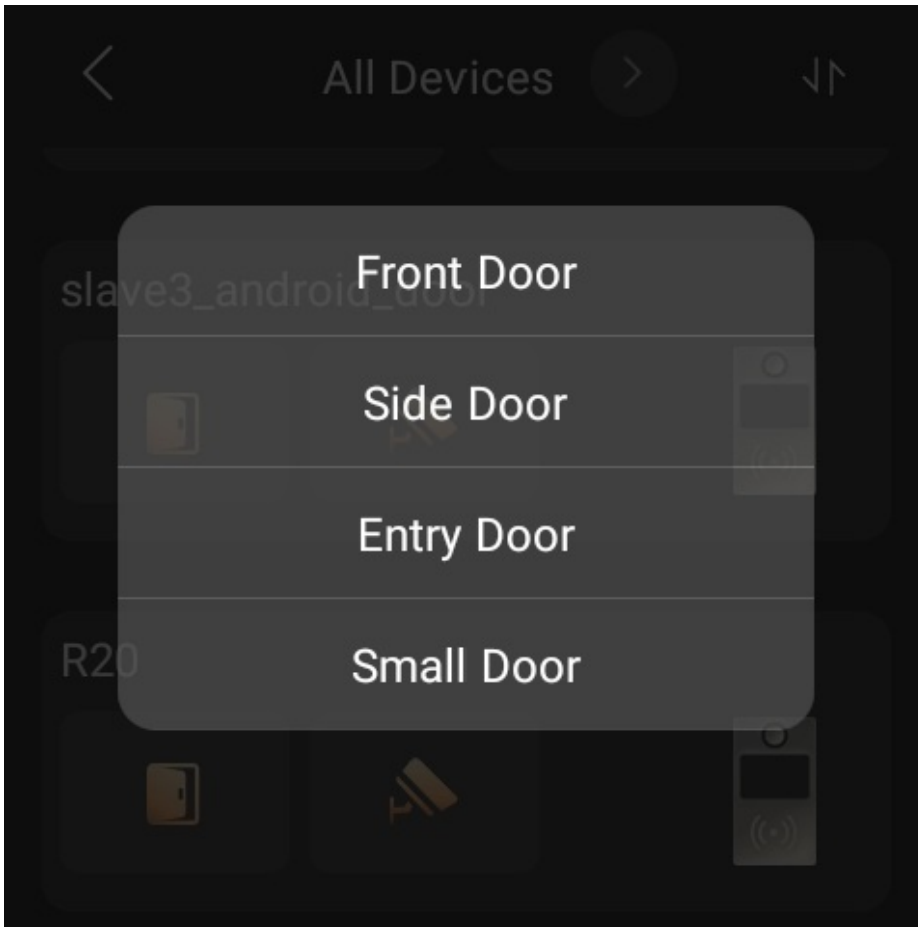

3. Tap **Confirm**.

Unlock door before answering a call

When you receive a call from the door phone with a camera, you can preview its monitoring streaming and open the door without answering the call.

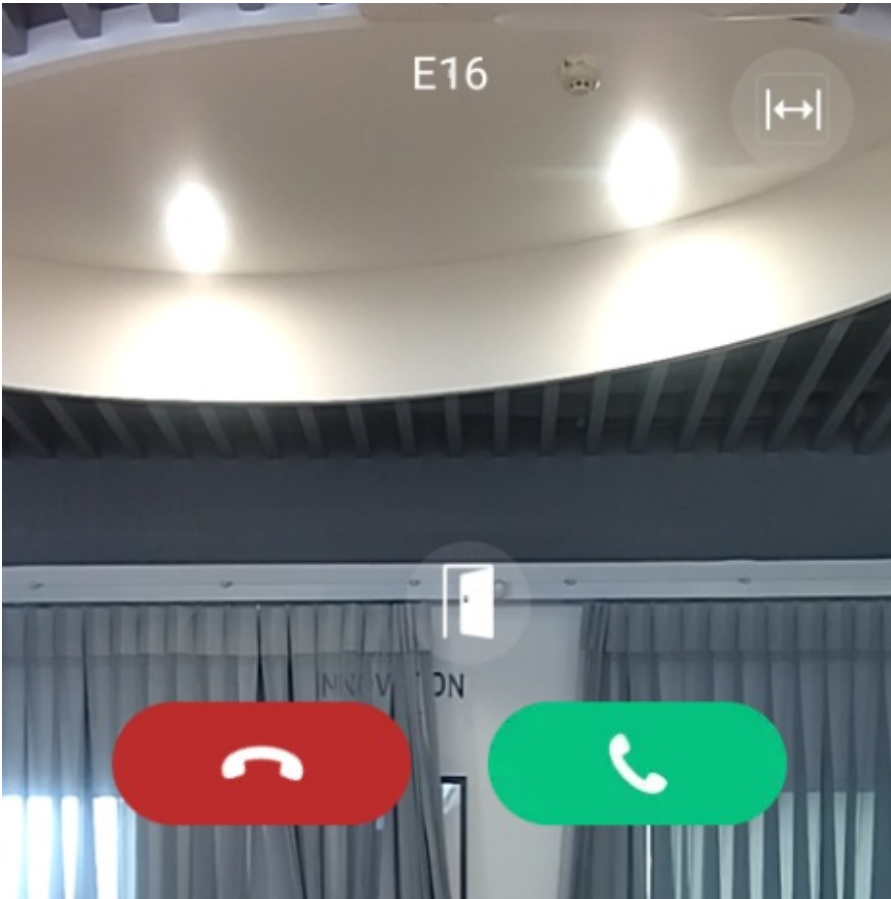

Unlock door during a call

You can answer the door phone call and unlock the door during the call.

On the calling screen, tap  to release the door.

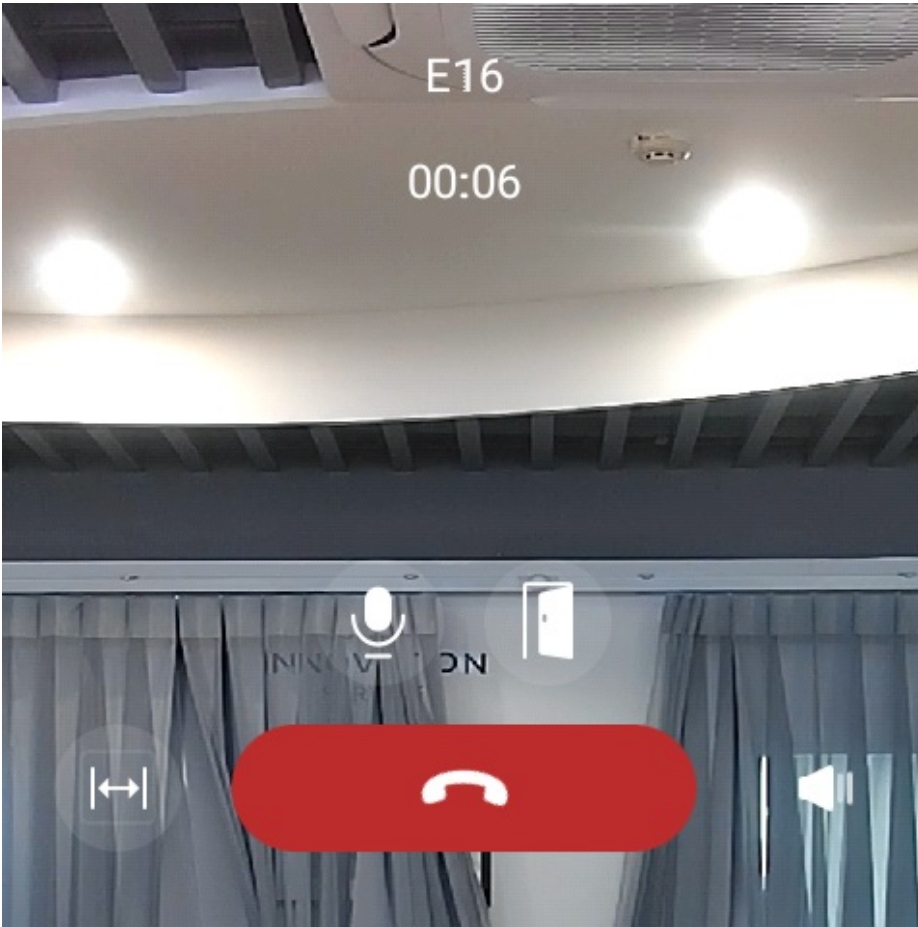

You are also able to call the door phone to see and hear who the visitor is. To do so, see the section *Make voice calls* in this guide.

See monitoring stream

If the connected door phone has a camera, you can see its monitoring stream on the HyPanel Plus. To see the monitor stream, find the desired door phone, and tap on the monitor icon .

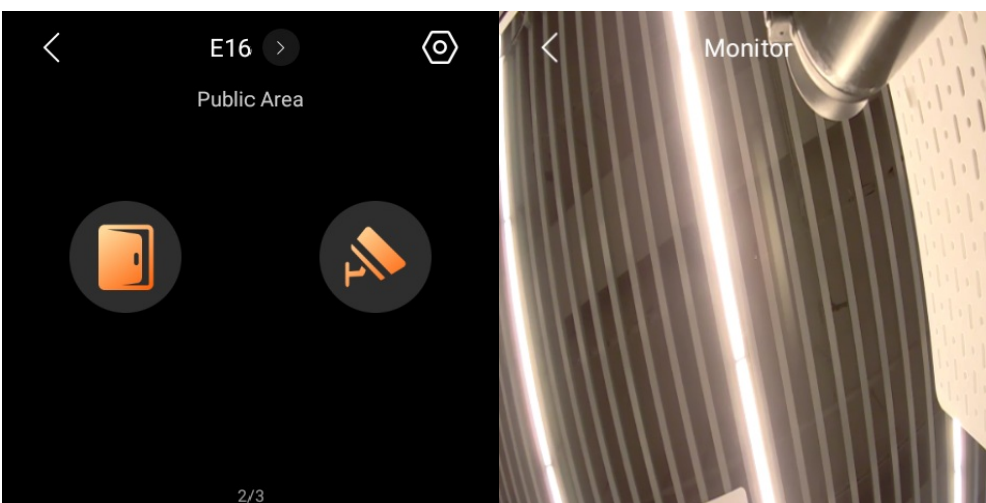

Energy

The Energy feature tracks the power consumption of your devices, rooms, and whole home.

NOTE:

- By default, the Energy feature is not displayed on the Functions screen. To access this feature, please go to the user web interface and enable [it](#).
- The Energy feature only applies to smart devices that support energy data collection.

1. Tap Energy .

2. On the Energy screen, you can see the previous day's data, including:

- The whole home power usage data showed in the center of the circle.
- Top 3 power consumers.
- Total energy consumption of the rooms excluding the top 3 (Other).

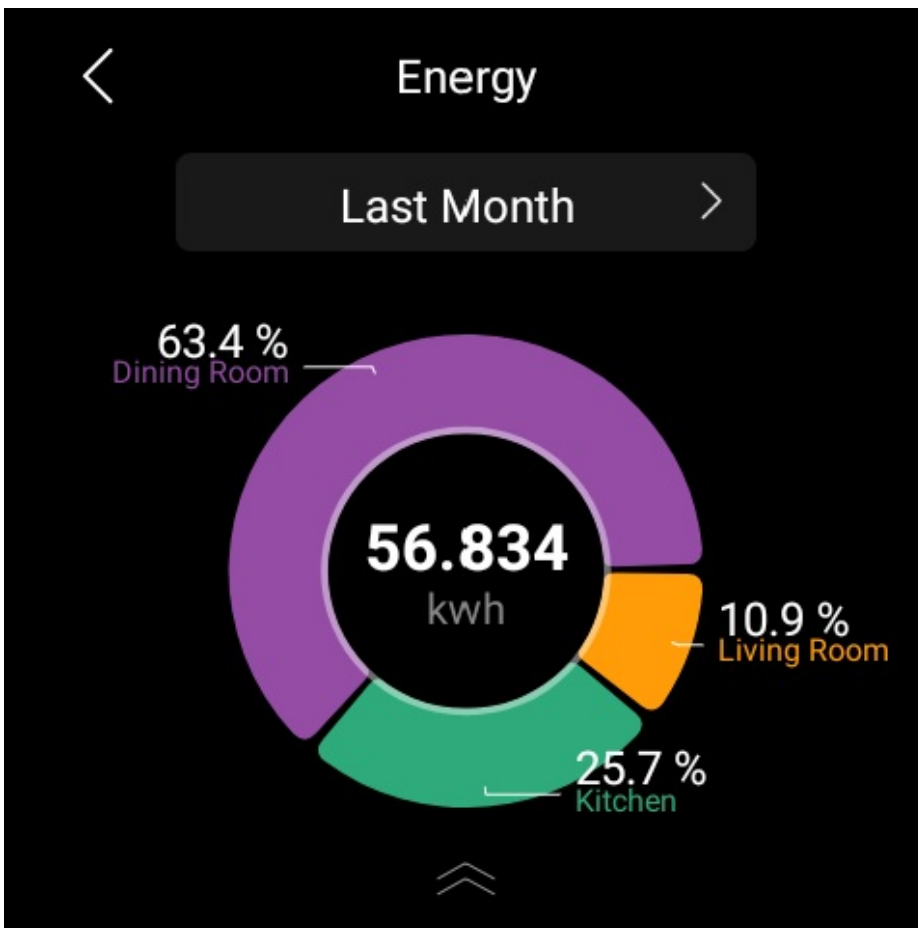

3. To see energy consumption of last week, or last month, tap  next to the time period.

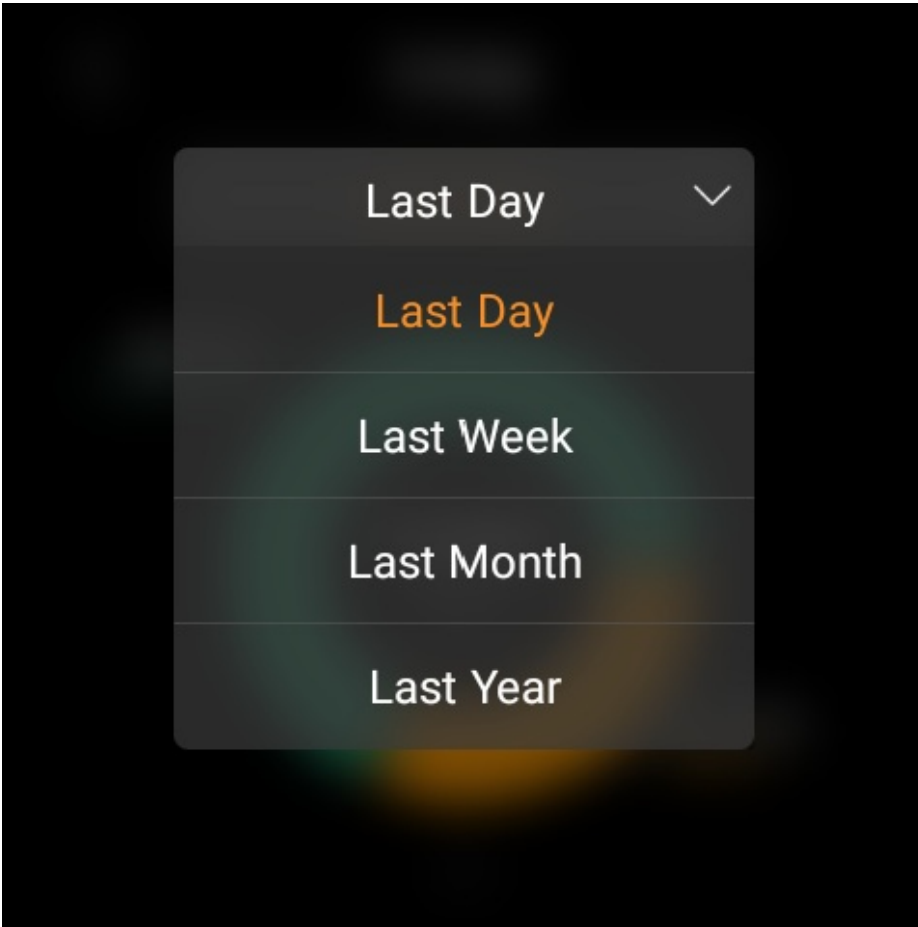

4. To track each room's power usage, swipe up from the bottom of the screen. The details screen opens.

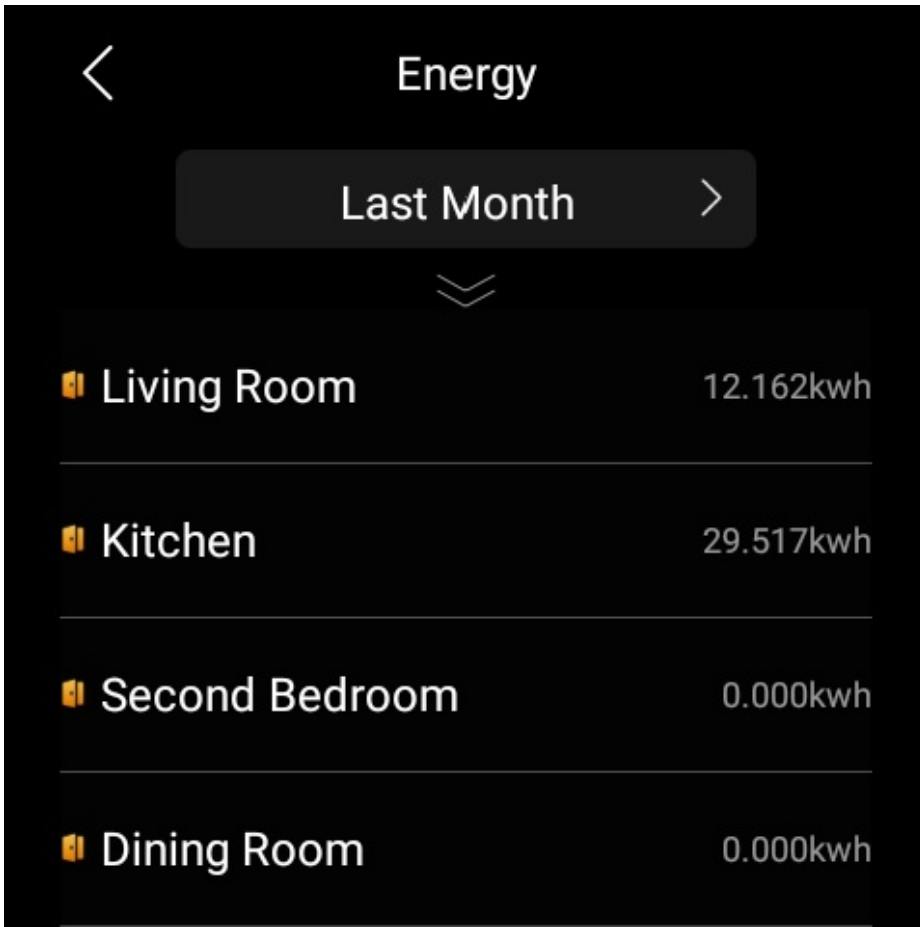

5. Tap the desired room to see each device's power usage.

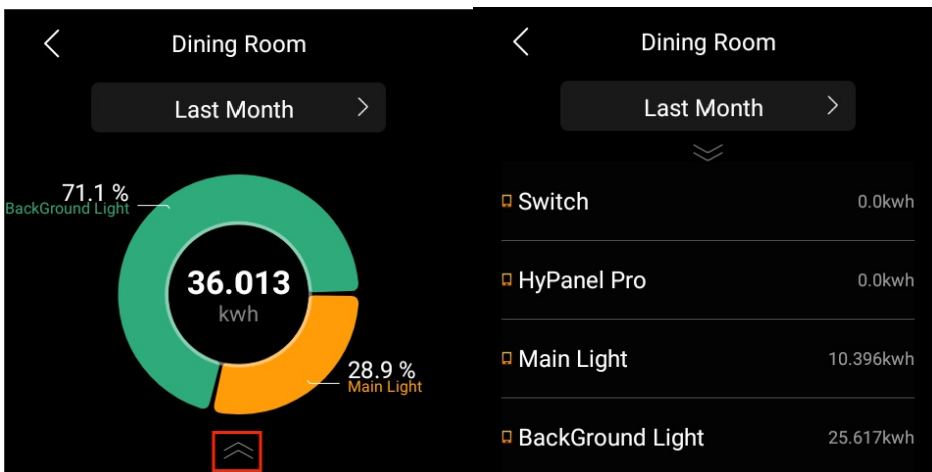

Integration

HyPanel Plus can integrate with Apple HomeKit and Amazon Alexa, providing effortless and convenient home control.

Amazon Alexa

By integrating with Alexa, you can voice-control all your Amazon devices by HyPanel Plus.

1. Swipe down from the top edge of any screen, then tap  > **Integration > Amazon Alexa > Log in to Amazon.**

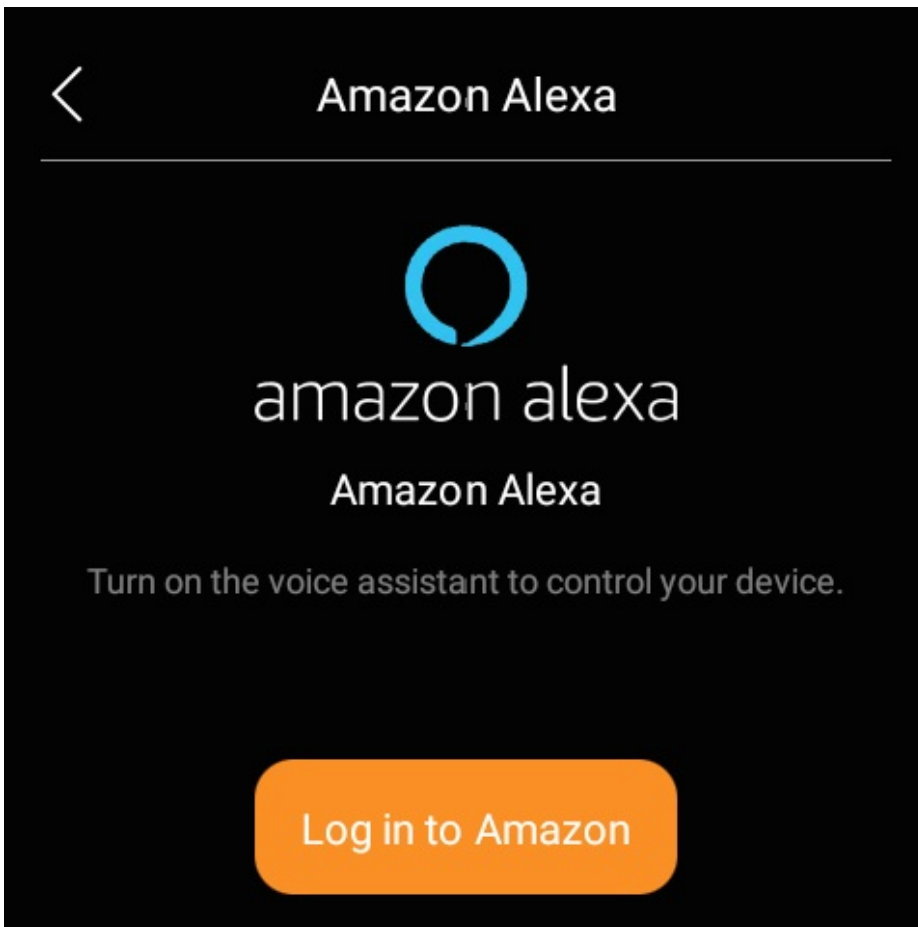

2. Tap **Copy the code and browse** after a code is displayed.

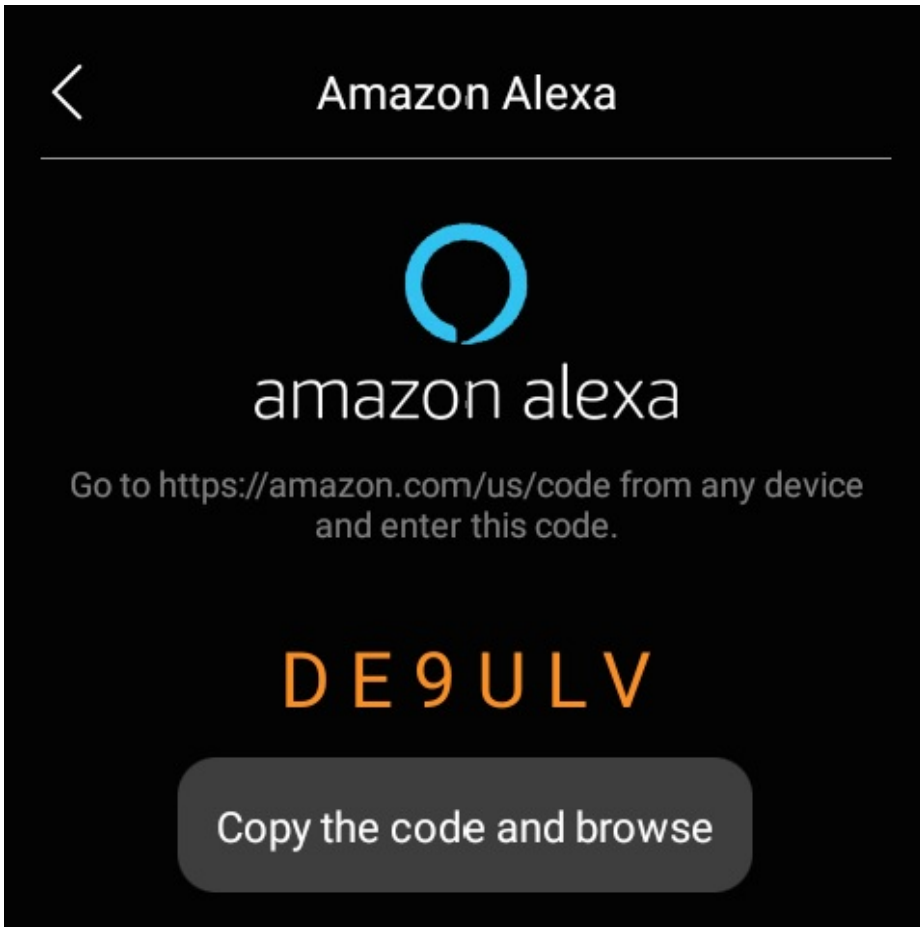

3. Sign in with your amazon account.

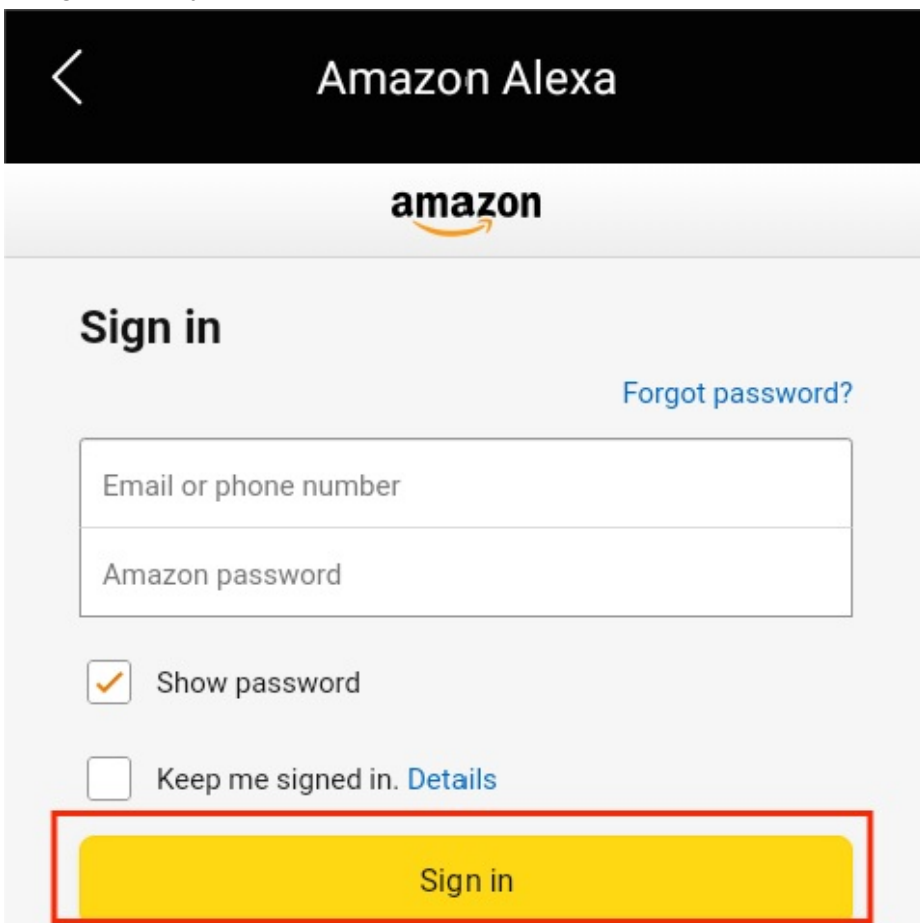

4. Long press the box to paste the code, and tap **Continue**.

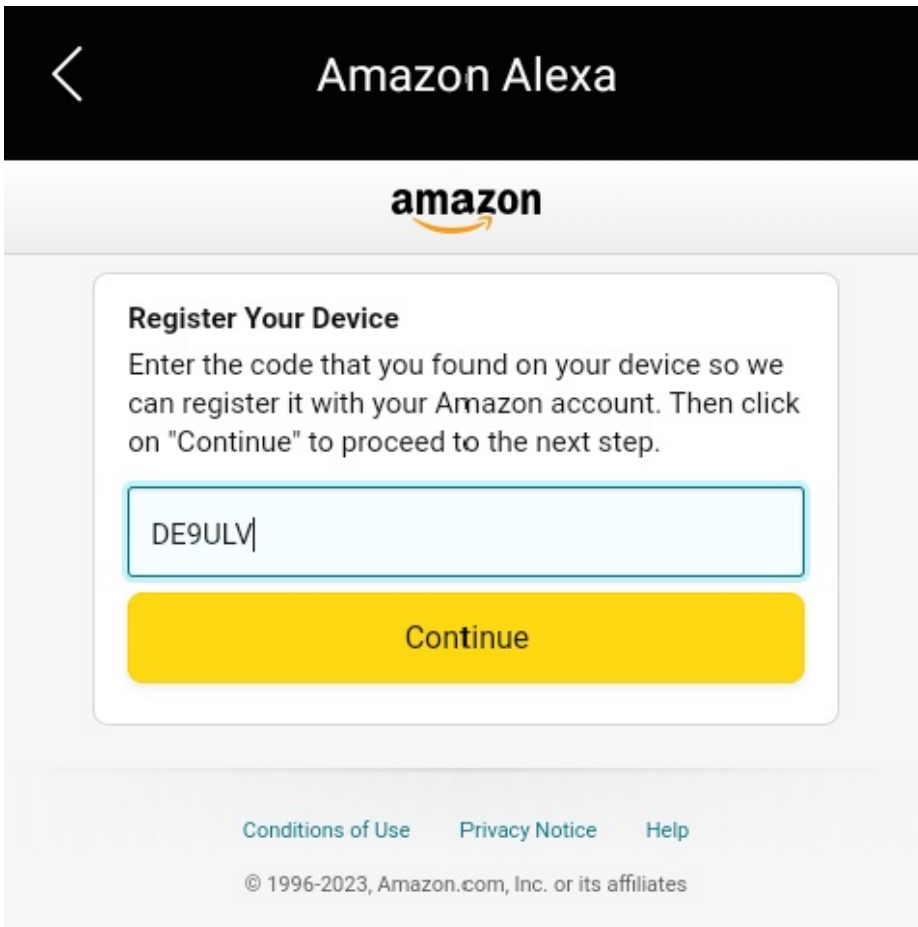

5. Follow the onscreen instructions until you see the screen below.

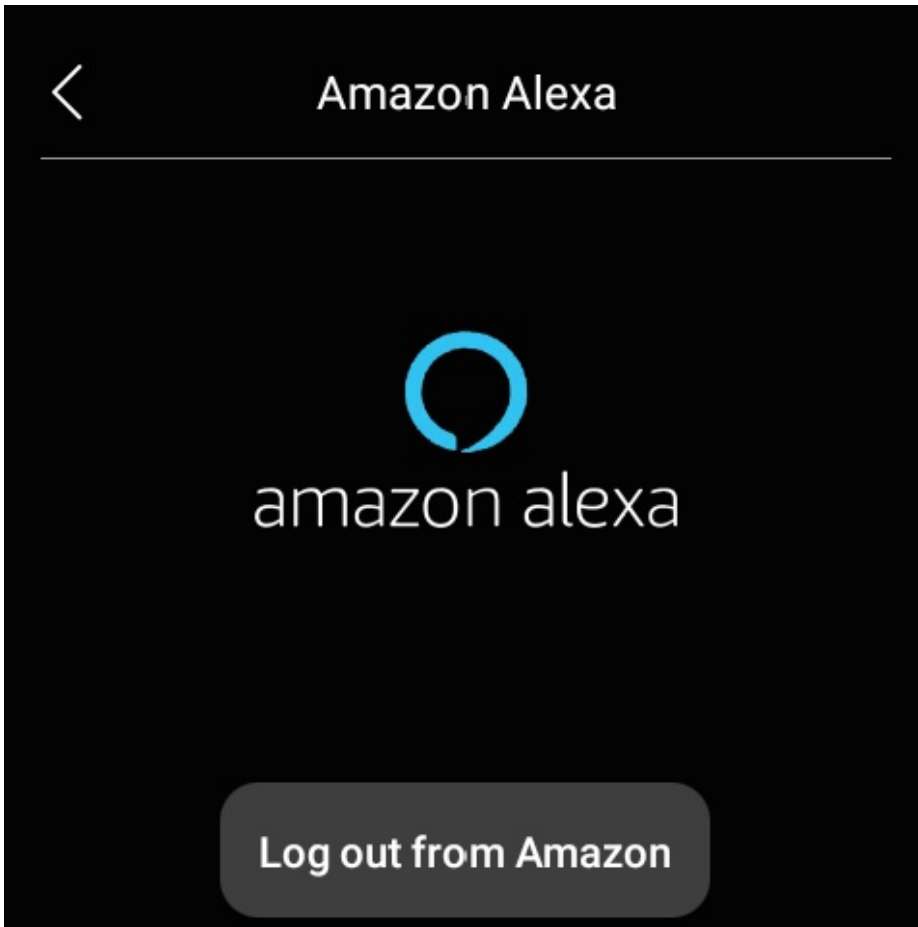

Once completed, you can voice-control devices and manual scenes on Akubela panels. To do this, Simply say "Alexa". You'll hear a sound response and see a blue light bar, which means it's waiting for your voice command.

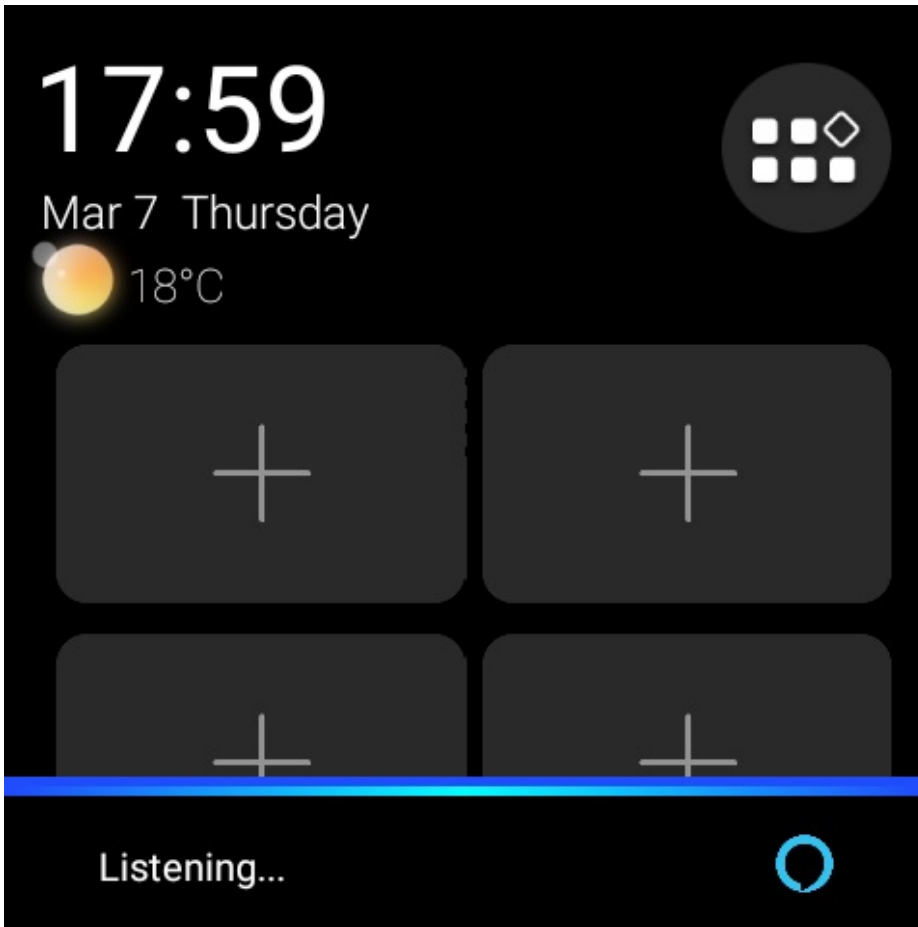

Apple HomeKit

After integration, you can effectively control all devices connected to HyPanel Plus devices using Apple's Home app.

1. Make sure your Apple device is on the same network with the HyPanel Plus.
2. Swipe down from the top edge of any screen, then tap  > **Integration** > **Apple HomeKit**. The following screen displays.



3. Open the Home app on your Apple device, log in with your iCloud account and continue to tap **Add or Scan Accessory**.

4. Scan the QR code.

5. Tap on **Add to "Apple Home"**. Follow the onscreen instructions to add all your devices and set them up.

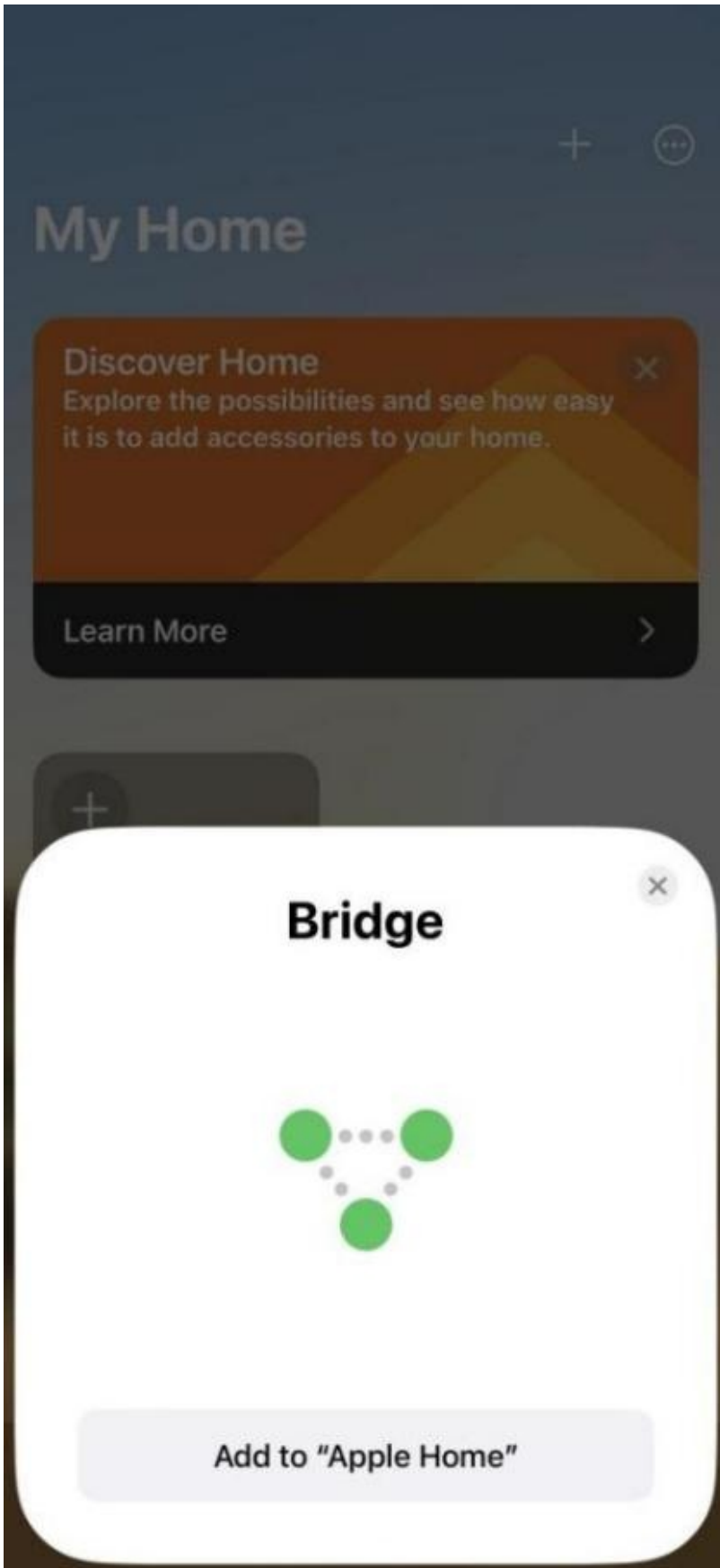

Once completed, all added devices are accessible within the app. Additionally, a successful confirmation screen is displayed on the HyPanel Plus.

You can control added devices directly on the Home app or via Siri. Refer to [this page](#) for common Siri commands.

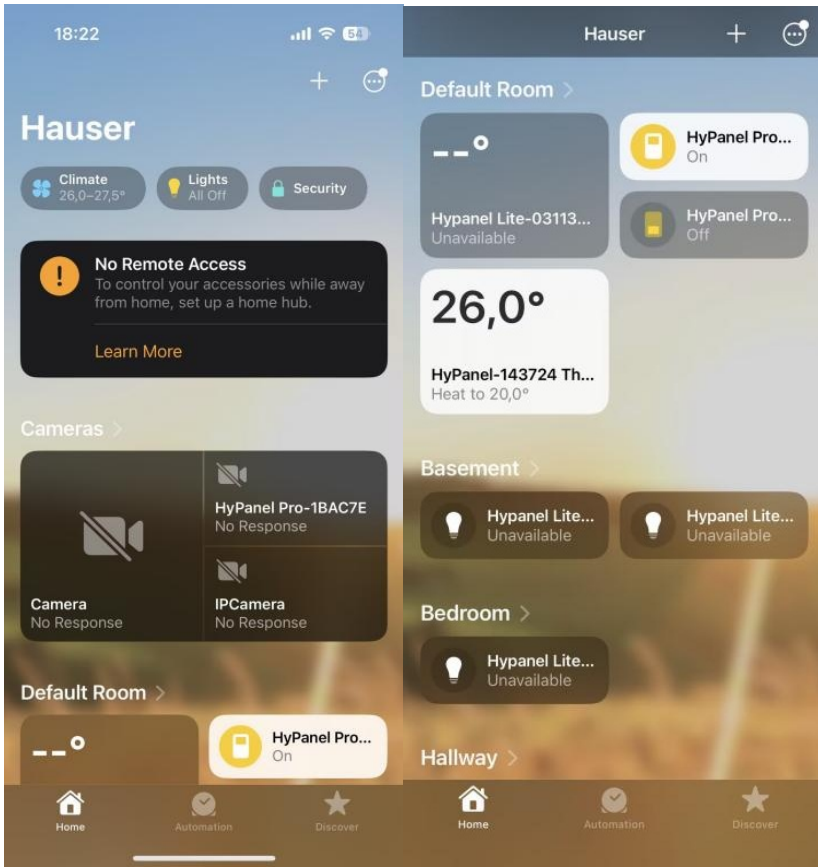

Third-party applications

HyPanel Plus allows for installing third-party apps through its engineering web portal. If you need to install any third-party apps, please contact your service provider.

Upon successful installation, the app will be accessible on the Functions screen for convenient use.

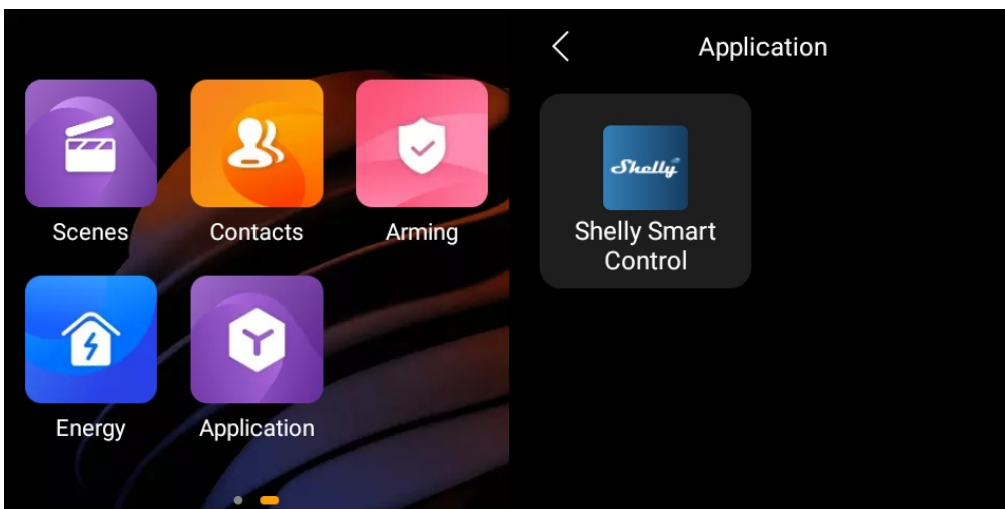

Home Automation

Scenes let you control your smart devices based on an action, an event, a schedule, or sometimes with a simple tap. For example, automatically turn off the light when you leave, and play music when you're back home.

NOTE:

Before you can automate your home devices using Scene feature, you need to create scenes on either the [user web portal](#) or [BelaHome app](#).

Activate your scene

Automation scene types

The following are three types of automation scene.

- **A scene only with auto condition(s)** is a scene set to be activated based on a schedule or an event.

NOTE:

This type of scenes are not displayed on the HyPanel Plus screen. You can see them on [user web portal](#) or [BelaHome app](#).

- **A scene with the manual condition** is a scene set to be activated based on a tap or click on the scene image.
- **A scene with both auto and manual conditions** is a scene based on a schedule, an event, and a tap or click. When any of the conditions is met, the scene will be activated.

Run a scene with manual activation conditions

On the **Scenes** screen, to activate a scene with manual trigger condition, just tap its image. Its background will be highlighted and then back to be dimmed to show that the scene is activated.

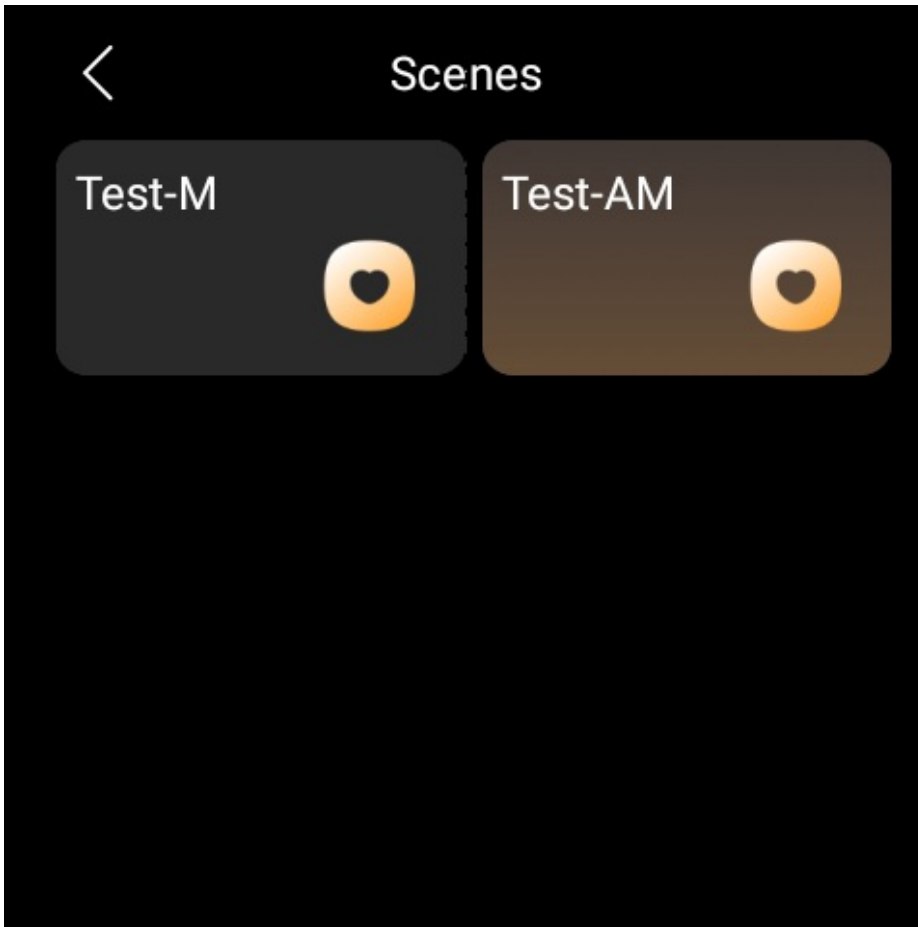

Run a scene with time or action conditions

You do not have to do anything to run an auto scene. Once the preset conditions are met, the scene is activated automatically. You can log into the user web portal or BelaHome app to see auto scenes without a manual trigger condition.

Security

Use security modes to easily control and protect your home.

NOTE:

- By default, the Arming feature is not displayed on the Functions screen. To access this feature, please go to the user web interface and enable [it](#).
- To arm your system, you must firstly configure three default security modes, or create custom modes on either the [user web portal](#) or [BelaHome app](#).

Arm your system

To arm your system after you configure the security modes, do as the following:

1. Select **Arming** .

2. Tap the desired mode, and enter the arming code (By default is 000000.)

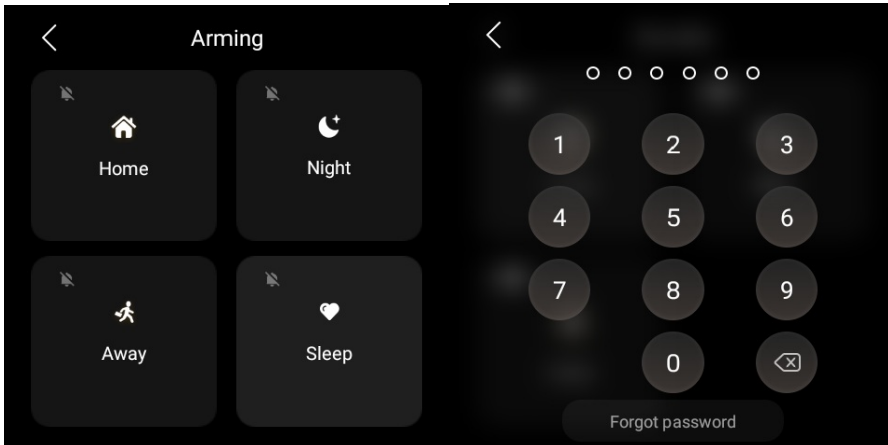

3. Wait for the arming count down to the end. Or tap **Skip** to arm your system right away.

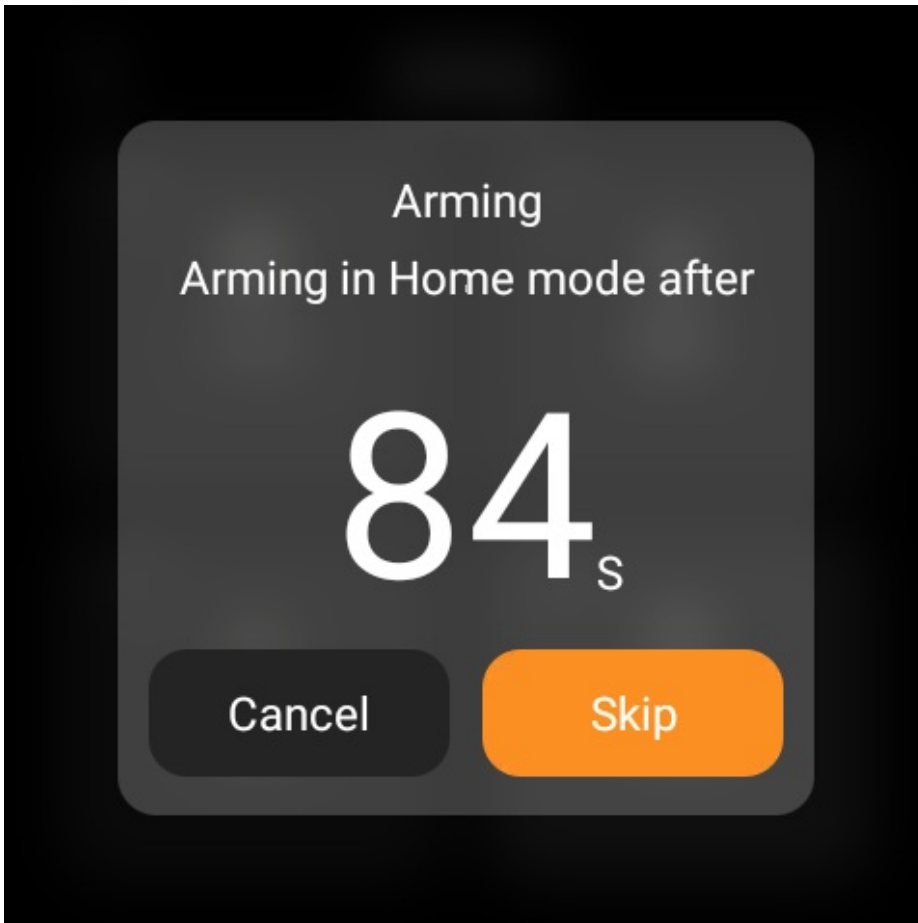

TIP:

The arming delay time can be modified on the [user web portal](#) or [BelaHome app](#).

4. Once the system is armed, the selected security mode icon is highlighted.

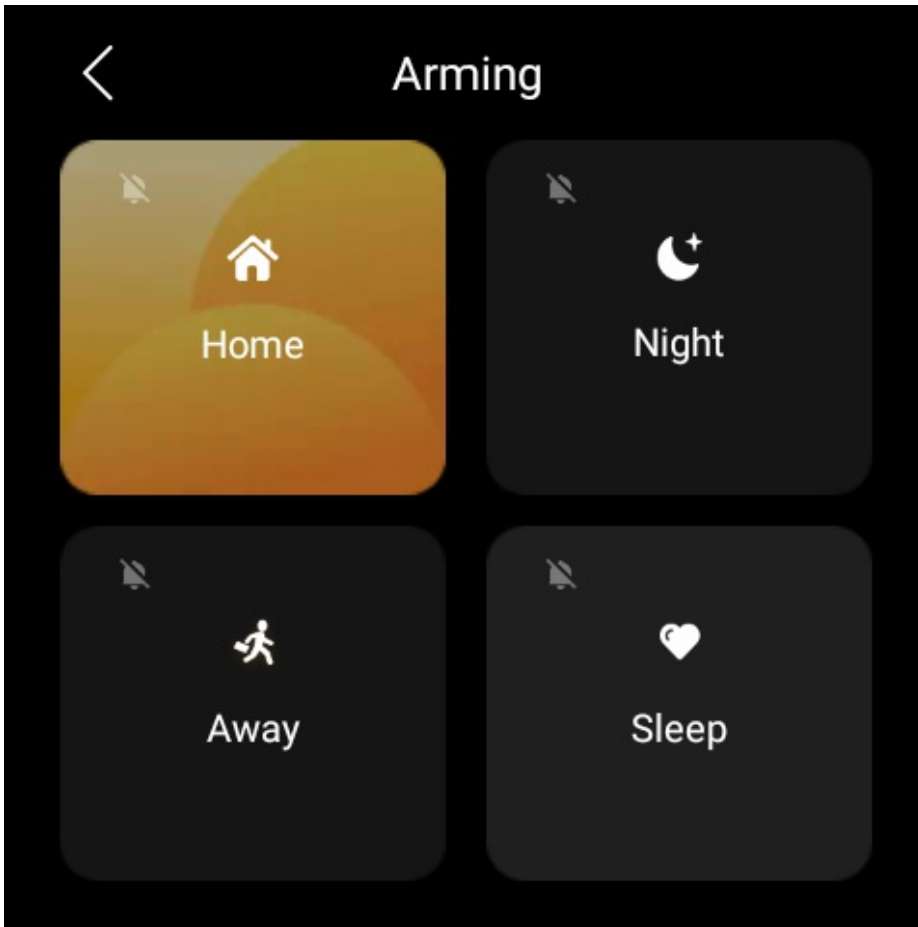

During the arming process, if any associated sensor is detected as abnormal, a prompt will appear.

- To identify the malfunctioning sensor, tap **Detail**.
- To proceed with the arming process despite the issue, simply tap **Ignore**. In this case, even if the bypassed device detects an abnormality, it will not send any alarms.

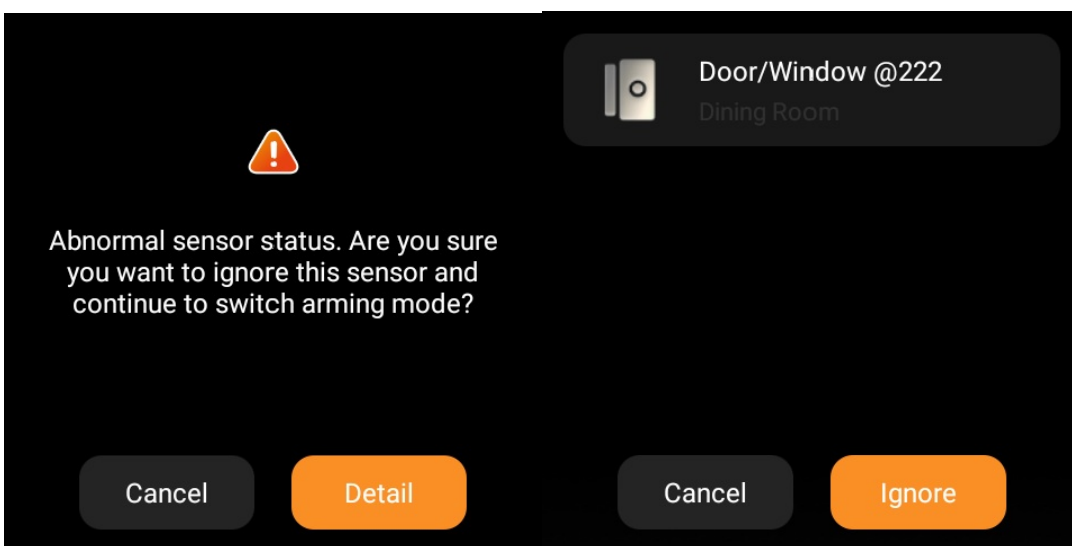

Disarm your system

To disarm your system, tap the highlighted mode image again, and enter the disarm code which is 000000 by default. You'll know the system is disarmed when the mode image turns back to be dim.

Deal with an Alert Push

When your system is armed in a security mode and any included sensor triggered(except the bypassed ones), the system will sound an alarm and send a notification to the panel and BelaHome app.

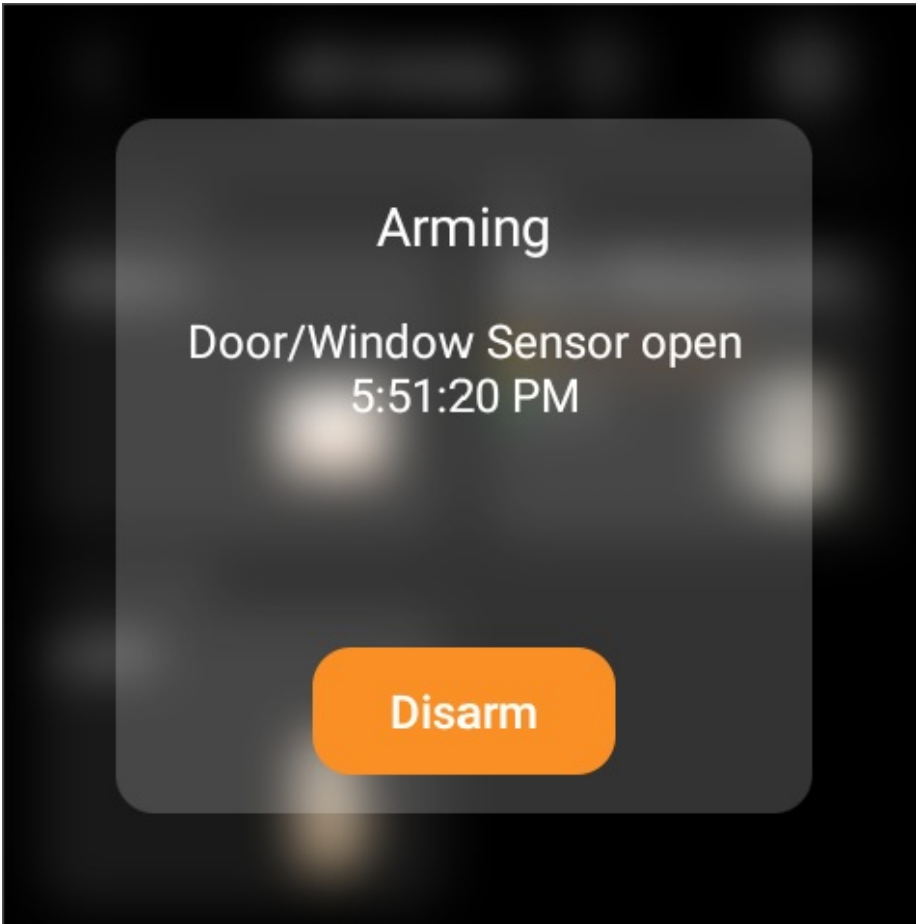

To stop the alarm once you make sure your home and family are safe, tap **Disarm** and then enter the preset code (By default is 000000). Your system is still armed in the security mode after the alarm is dealt with.

Disable siren and alerts

By default, your device emits a siren and sends a push notification when any sensor is triggered while in the armed mode. You can silence the siren and disable push alerts from the panel.

NOTE:

Even when silenced, alerts and notifications will still be sent to guard phones and the BelaHome app.

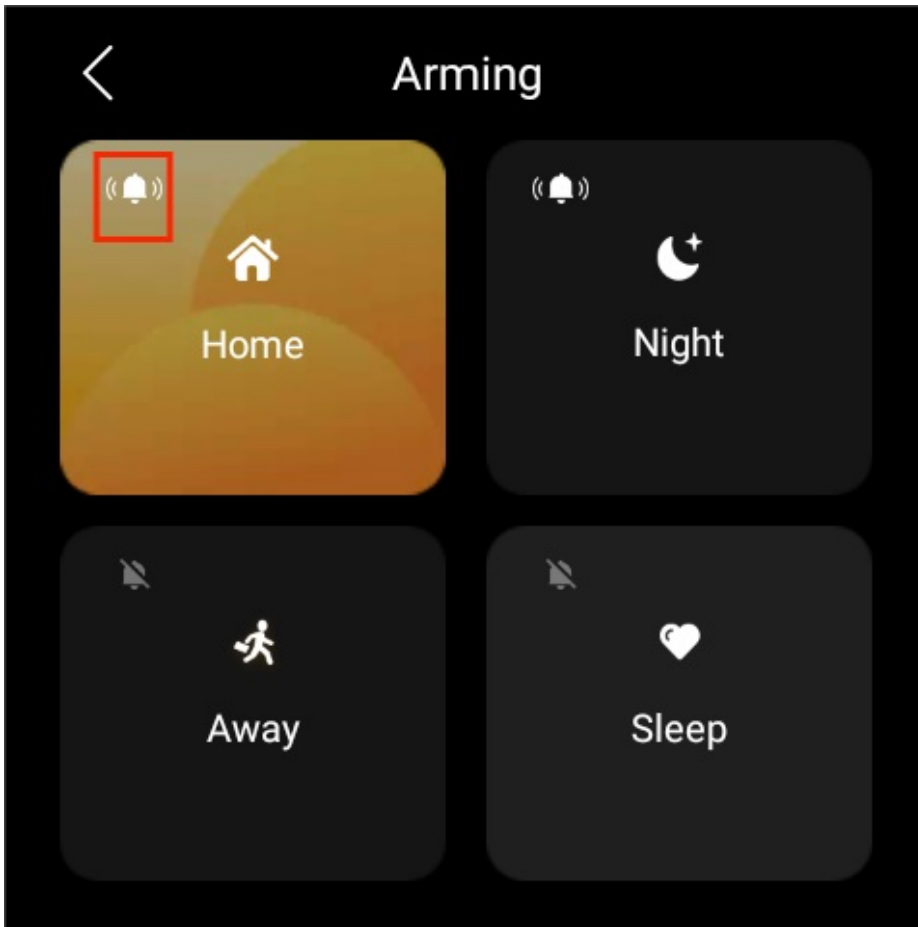

1. Select **Arming**  and tap the bell icon  at the left corner of the scene image.

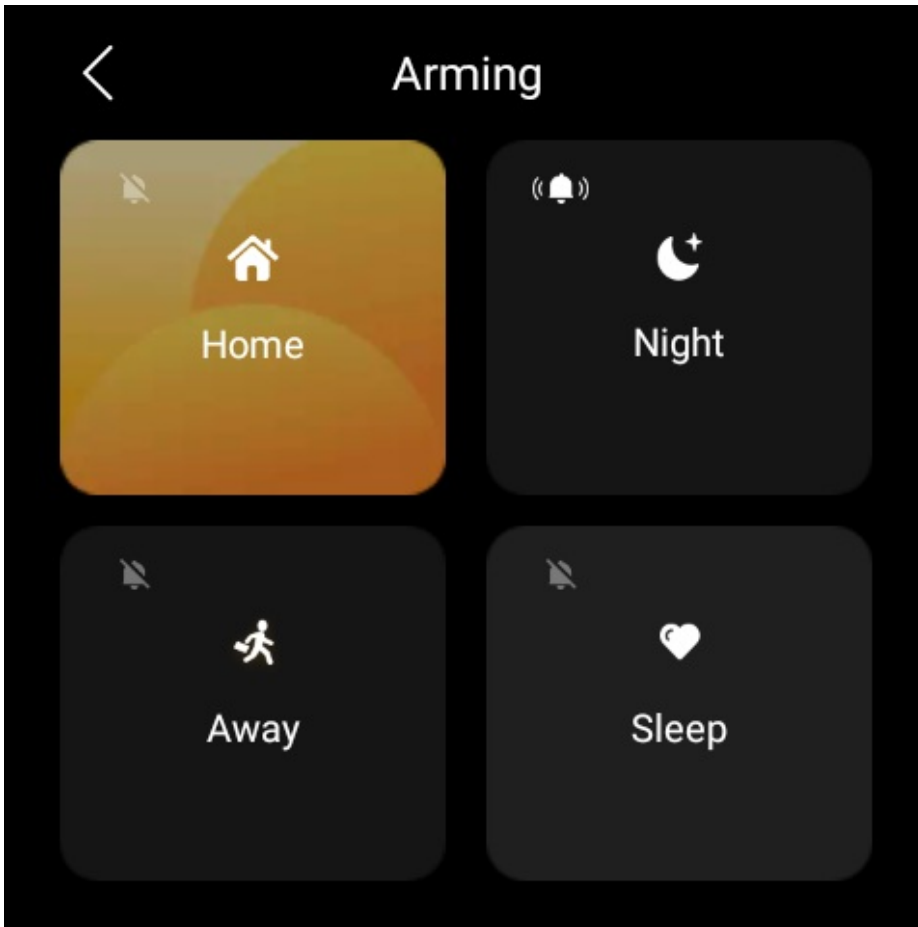

2. Enter the code which by default is 000000.

3. The siren feature is disabled when you see the icon turns to . Please note that in this case, all panels will not activate a siren and send push alarms.



To enable the siren, tap , and enter the preset code. The icon turns to be  indicating that the siren function is on.

Forgot arming/disarming code

To restore the default password, 000000, tap **Forgot Password** on the password required screen and follow the onscreen instructions. Two resetting options are provided based on your cloud connection status.

- Via reset email

If you've registered the administrator account and ensure that the devices are connected to the Internet, a code reset email will be sent to the family's administrator email address once you tap **Forgot Password**. Follow the instructions included to restore the default password.

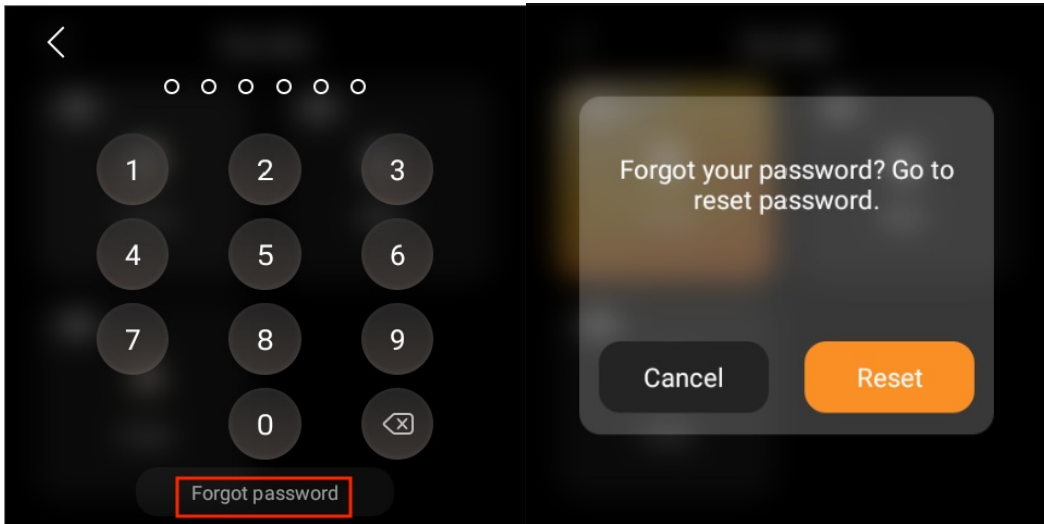

- On the user web portal

Visit the [user web portal](#), and click **Settings > Change Security Code**.

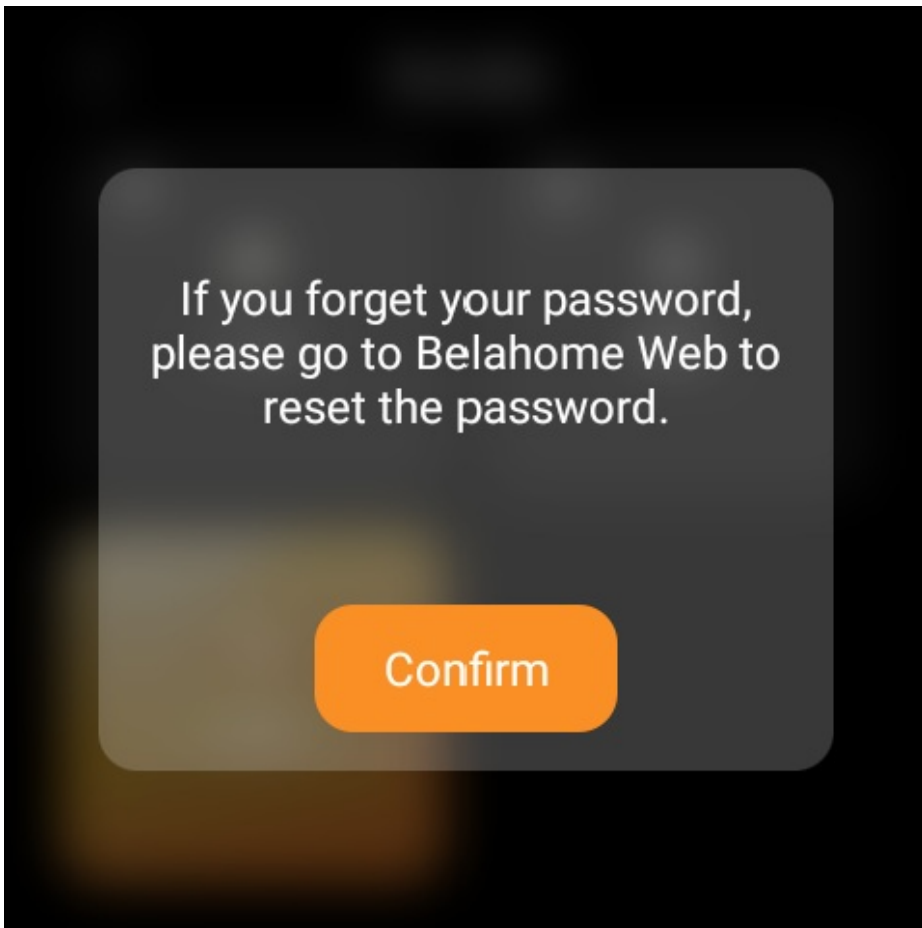

Communication in Family

You and your family members can make calls with each other, and send and receive messages at any time through HyPanel Plus.

Register family administrator account

If you are the first person in your family to register the account, you will be the family administrator. Only the administrator of the family has the permissions to create and manage family member accounts.

Tip:

When the weather forecast displays on all panels, it indicates successful Cloud connectivity.



When devices connected to the cloud

To register the administrator account when your family's devices are connected to the cloud, you can either:

- Contact your service provider to register and activate your administrator account.
- Contact your service provider to connect your devices to the cloud, and self-register your account by following the steps below.

1. Tap **Account Registration** on the Functions screen, or go to  > **System Settings** > **About** > **Family** > **Family Account**. A QR code displays on the screen.

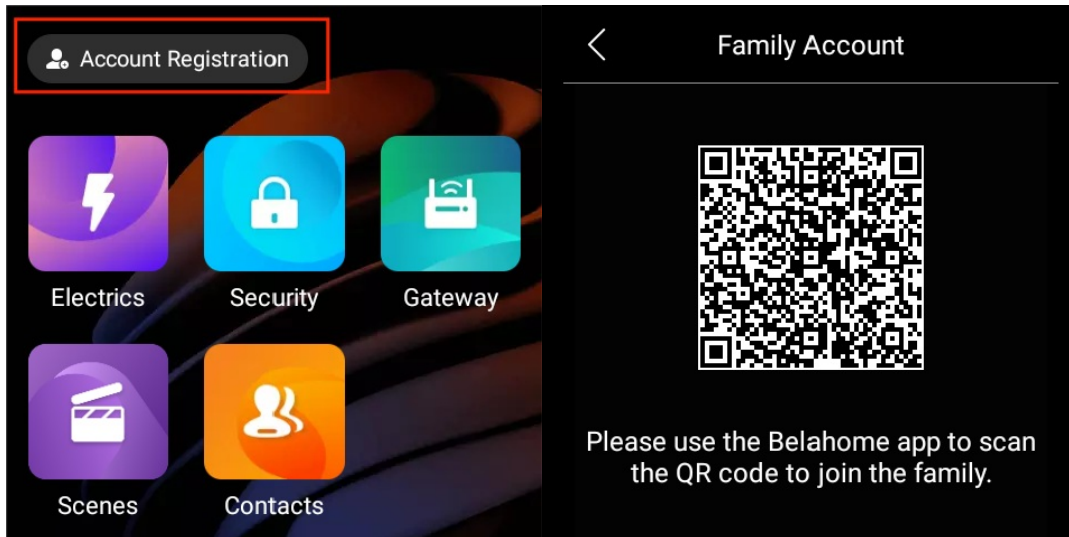

2. Do one of the following:

- If you already have an account associated with other families
 - a. Open BelaHome app, and log into your account.
 - b. Tap Me > Scan icon, and scan the QR code.

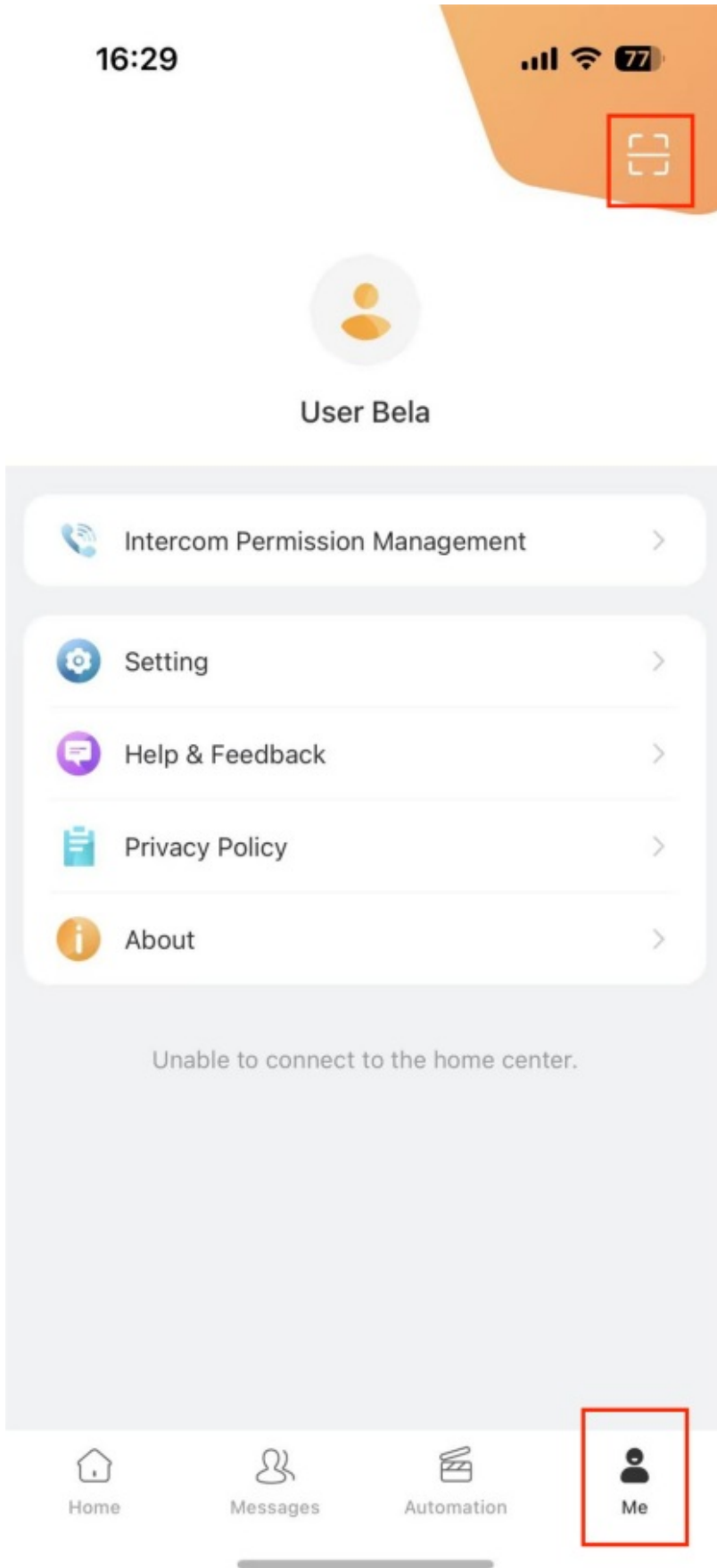

c. Tap Join the Family.

16:29



Join this family as the main account



Join the family

d. You can switch the families on the app's Home screen.

- If you are a new user

a. Open BelaHome app, and tap on the scan icon at the upper left.

15:40



BelaHome

Smarter Home, Sweeter Life



Log In

[Sign Up](#)

[Forgot Password?](#)

Server ID

b. Scan the QR code.

c. Enter a valid email address. The login credential will then be sent to this email.

15:40



< Sign up for Belahome account

Email

Please enter your Email

Sign Up

d. Log into the BelaHome app with the credentials you receive.

When devices running in Auto Discovery mode

When devices are running in Auto Discovery mode and never connected to the cloud, the temporary administrator account has default username and password that are both *Admin888*.

You can also log into the BelaHome app by scanning QR code:

1. Ensure that your phone and devices are in the same local network.
2. Go to  > **System Settings > About > Family > Family Account**. A QR code displays on the screen.
3. Open BelaHome app, and tap on the scan icon at the upper left.
4. Scan the QR code.

NOTE:

After setting a new password, scanning the QR code does not work for logging in.

Once logged in with the administrator account, you can create family member accounts on the BelaHome app. Click [here](#) to see detailed instructions.

Make voice calls

You can group call or make one-to-one call with any device, including the door phones, in your family, or family member's through HyPanel Plus. You can also receive their calls on HyPanel Plus.

To make calls, do as the following:

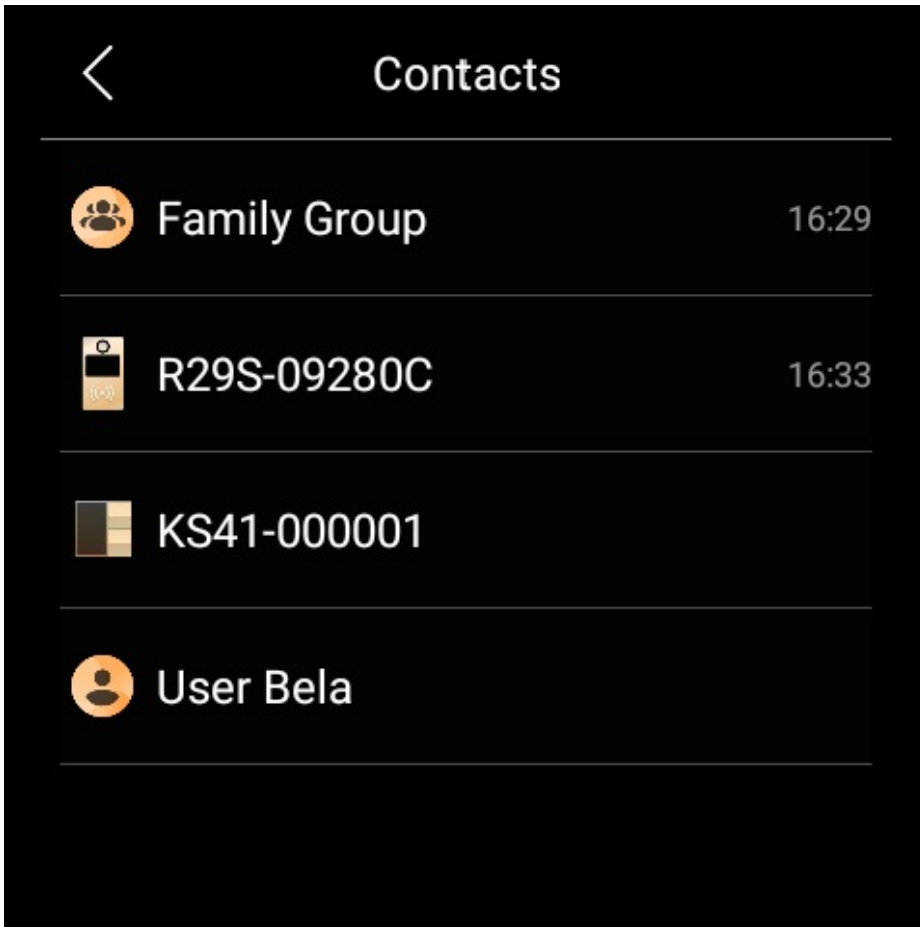

1. Select **Contacts**  on the Functions screen.
2. On the Contacts screen, do any of the following:
 - Tap Family Group to group call all panels within the family. They will auto-answer the call.
 - Select the family member or device you want to call.

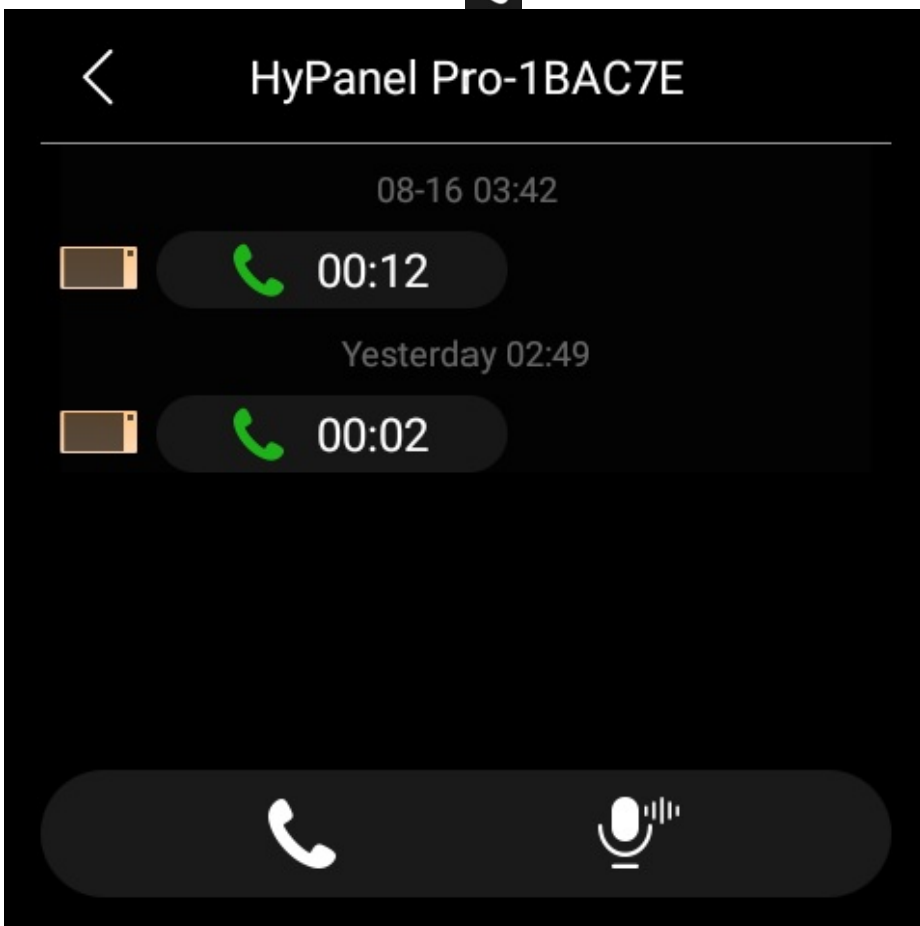

3. On the conversation screen, tap .





What else you can do on the voice call screen:

- Tap  to silence your microphone. Doing so, the call will not hear your voice.
- Tap  to adjust the volume.
- Tap  to hang up the call.

Send audio messages

HyPanel Plus allows you to send and receive voice messages.

1. Select **Contacts**  on the Functions screen.
2. Tap Family Group to send all contacts a message, or select any desired member or device to sent messages to.
3. In the conversation, tap and hold  at the bottom right to record an audio message.

Each message should be within 30 seconds. To cancel before sending, slide your finger to the left or upwards while recording.

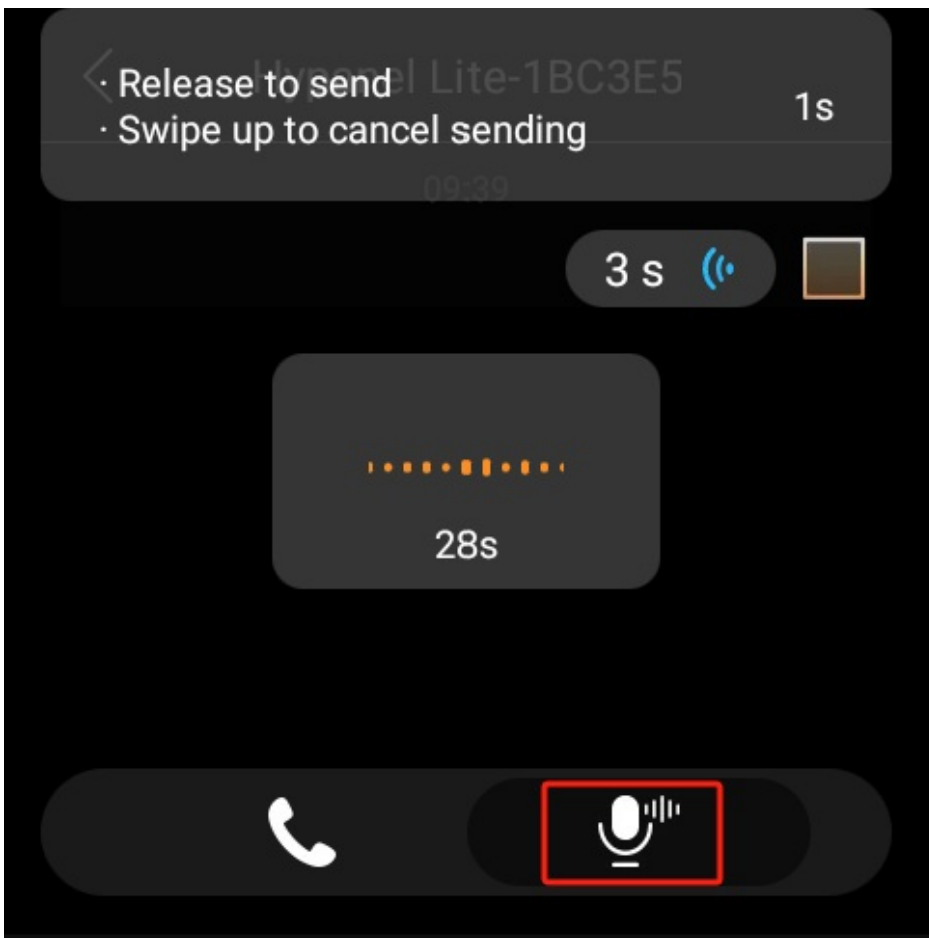

4. Lift your finger when you're finished recording.

Update, Restart and Reset

Update the system

Device update requires cloud connection. Alternatively, you can contact your service provider for assistance.

To update the device to the latest version, swipe down from the top edge of any screen, and tap 

> **System Settings** > **Update**. On the Update screen, do any of the following:

- To update the firmware automatically, toggle on **Auto Update**. You can also set a specific update time period for the device to download and install available updates.

NOTE:

To upgrade the device in the preset time, the device must meet below 2 conditions : a)The device is in the standby mode during the previous hour, and b)The device does not have alarm and countdown set for the next hour.

- If Auto Update is disabled, any available update must be downloaded and installed manually with your consent. To do this , tap **Update**.

NOTE:

If your system already installs the latest version, the screen shows no Update button.

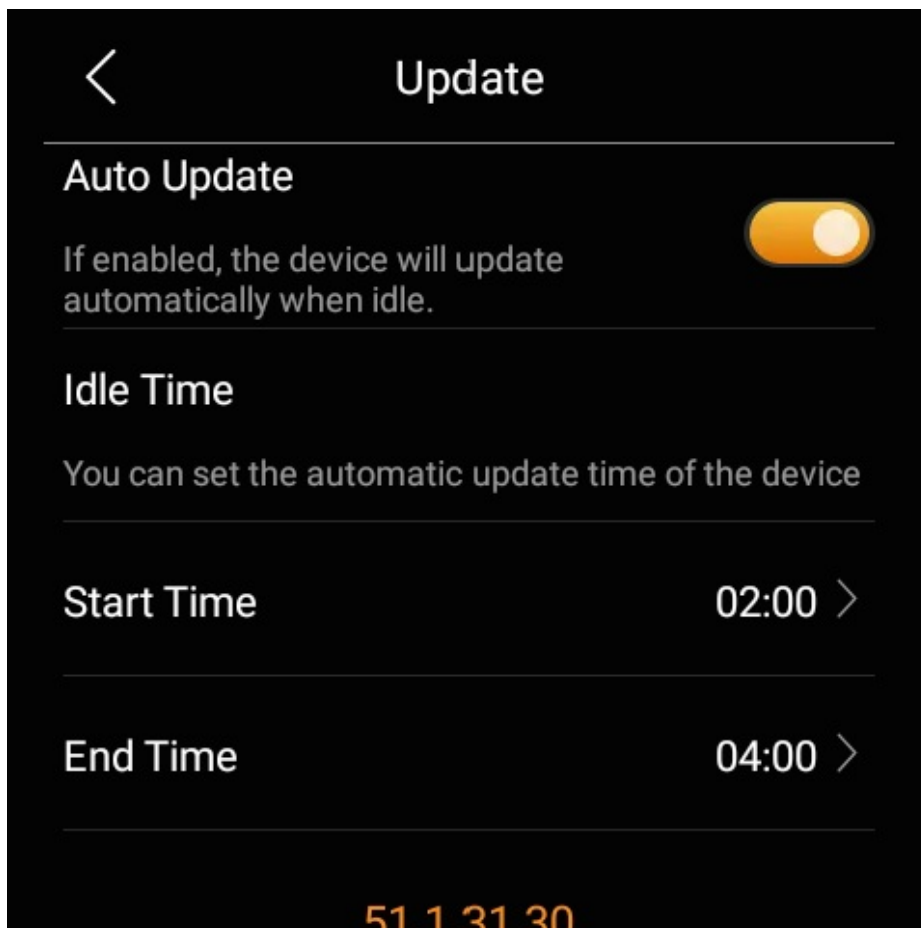

Restart your HyPanel Plus

To restart the system, do any of the following:

- Press the restart button at the bottom edge (refer to the picture) using a paperclip or needle until the display turns off.



- Swipe down from the top edge of any screen to open Control Center, and tap  > Reboot.

Restore HyPanel Plus to installer settings

To reset your device, do as the following.

1. Swipe down from the top edge of any screen to open Control Center.
2. Tap  > System Settings > Reset.

NOTE:

The reset results depend on the device's usage mode your service provider selected in the initial setup.

- Choosing the Installation Code option will reset the device to the settings that your installer set up, and remove all user data and subsequently added devices.
- Selecting Auto Discovery mode will initiate a reset to factory settings, and delete all user data and devices.

Please consult with your service provider before resetting devices.

Privacy Policy

As you use our services, you trust us with your information. We will keep working hard to protect your data. The Privacy Policy is meant to help you be clear about what information we collect, why we collect it, and how you can protect your privacy.

To read the Privacy Policy, do as the following:

1. Swipe down from the top edge of any screen to open Control Center.
2. Tap  > **System Settings** > **About** > **Privacy Agreement**.

Get Help

For videos and other manuals, visit <https://knowledge.akuvox.com>.

For help, contact us at <https://ticket.akuvox.com/>.